

# SERVICE MANUAL

FOR

## L. E. MODEL

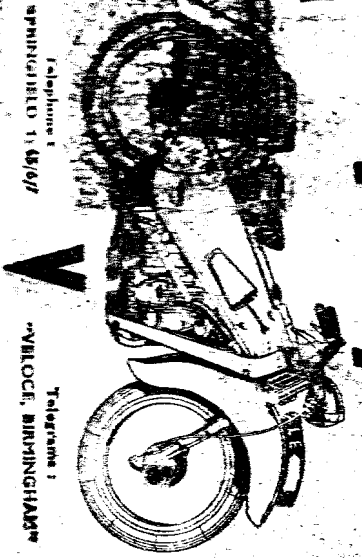

Telephone :  
SPRINGFIELD 11 61/67



Telephone :  
"VELOCE, BIRMINGHAM"

**VELOCE LTD.**  
GREEN, BIRMINGHAM, 26

25  
12  
150  
250  
000

## FOREWORD

This Manual has been produced as a complete guide to the repair and maintenance of the Velocette L.E. Model.

There are many references to special service tools and equipment, and these have been designed and made mainly for Service Agents' use, as they are essential to anyone undertaking extensive repairs and overhauls to this type of machine if the work is to be made easy, carried through without damage to components, and completed in the shortest possible time, with consequent economy in labour costs.

They are not likely to be required by private owners, nor would such persons find sufficient use for them to justify their purchase. For a Service Agent they are a necessity, and we strongly urge that all Agents should equip their workshops with them.

We have tried to keep the instructions as simple as possible and have included illustrations to make them clearer where we have thought they were needed.

When references are made to unscrewing and tightening bolts and lock rings, etc., it must be taken that all threads are right handed. Remember also that where "Tighten" is stated, over-tightening may cause serious damage through stripped threads or broken bolts and studs.

VELOCE LTD.,  
SERVICE DEPARTMENT.

Ref. No. F.456/I.R./5m.

March 1952.

## CONTENTS

	<i>Pages</i>
Battery .. .. .	81
Bevel Drive Casing .. .. .	12
Bevel Pinion and Crown Wheel .. .. .	50
Brakes .. .. .	73
Camshaft .. .. .	32, 41
Carburetter .. .. .	85
Clutch .. .. .	19
Clutch Thrust Rods .. .. .	13, 14
Clutch Cable .. .. .	75
Crankshaft .. .. .	36, 38
Cylinders and Cylinder Heads .. .. .	24
Decarbonising and Grinding in Valves .. .. .	24
Frame. Removal of .. .. .	8, 29
Frame. Reassembly of .. .. .	46
Front Fork .. .. .	68
Flywheel Housing .. .. .	33, 34, 39
Flywheel. Removal and Refitting of .. .. .	43, 64, 66
Gearbox .. .. .	12, 45
Generator .. .. .	76
Hubs .. .. .	72
Ignition Timing .. .. .	50
Pistons .. .. .	30
Piston Rings .. .. .	42
Radiator and Cooling System .. .. .	71
Rear Fork .. .. .	11
Rear Springing .. .. .	70
Reduction Gear Plate .. .. .	31, 42
Starter Segment .. .. .	22
Starter Spring .. .. .	46
Steering Column .. .. .	47
Tappet Adjustment .. .. .	23
Universal Joint .. .. .	59
Valves .. .. .	25
Wheels .. .. .	71
Wiring Diagrams .. .. .	77, 83, 89

## Index to Illustrations

		<i>Page</i>
Figure 1	Oil filler and dipstick, etc. .. .. .	6
" 2	Bevel casing filler and level plugs, etc. .. .. .	7
" 3	Rear part of frame lifted .. .. .	9
" 4	Gearbox being withdrawn from clutch housing .. .. .	10
" 5	Clutch and nuts at bottom of clutch housing .. .. .	10
" 6	Removal of rear fork pivot pins .. .. .	11
" 7	Rear fork assembly withdrawn .. .. .	13
" 8	Arrangement of clutch thrust rods (early type) .. .. .	13
" 9	Arrangement of thrust rods and thrust pin (later type) .. .. .	14
" 10	Gearbox end cover oil seal tool .. .. .	15
" 11	Oil seal fitting tool LET786 with collars, etc. .. .. .	15
" 12	Selector shaft finger and interlocking gate .. .. .	16
" 13	Gearbox top cover and gear lever end .. .. .	17
" 14	Arrangement of gearshafts and gears .. .. .	18
" 15	Selector forks and plunger holding tool .. .. .	18
" 16	Lock ring spanner LET780 .. .. .	19
" 17	Clutch shown dismantled .. .. .	20
" 18	Assembly of starter pawl springs and reduction gear .. .. .	21
" 19	Clutch alignment tool LET791 .. .. .	22
" 20	Tappet locking tool LE518 .. .. .	23
" 21	Valve cotter removal and order of tightening cylinder nuts .. .. .	25
" 22	Valve seating cutter and pilot LET686 .. .. .	26
" 23	Valve lapping tool LET687 .. .. .	26
" 24	Order of tightening cylinder head nuts .. .. .	28
" 25	Carburetter to induction pipe gasket .. .. .	29
" 26	Oil pump suction bolt .. .. .	30
" 27	Timing pinion lock ring tool LET780, also showing crankshaft "chocked" .. .. .	31
" 28	Crankshaft pinion extractor LET802 .. .. .	32
" 29	Connecting rod extraction slots in use .. .. .	33
" 30	Oil seal centralizing bush LET793 .. .. .	34
" 31	Flywheel housing extractor LET937 .. .. .	34
" 32	Crankshaft ballrace extractor LET928 .. .. .	35
" 33	Crankshaft pressing fixture LET807 and packing strip LET910 .. .. .	36
" 34	Crankshaft assembly, connecting rods, oil receiver cup, etc. .. .. .	37
" 35	Flywheel housing and ballrace assembly tool LET924 .. .. .	39



## LUBRICATION.

### Engine, Gearbox and Final Drive Casing.

When taking over a new machine check all oil levels : Engine, gearbox and final drive casing. The engine oil dip stick is fitted on the left-hand side below the filler cap (Fig. 1). The gearbox oil level must be just up to the filler plug opening. The oil in the final drive casing must be just up to, but not overflowing from the level plug when the machine is upright. The level plug is fitted about one inch lower than the filler plug (Fig. 2) and is the smaller one.

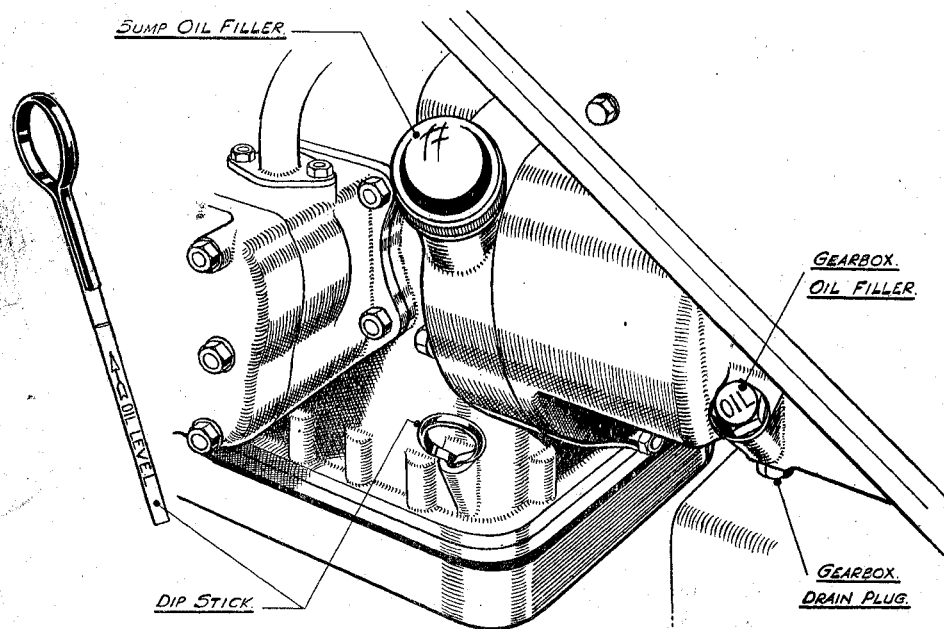

FIG. 1.

Subsequent checks are best made when the oil is warm, but the machine should be left standing long enough for the oil to drain off the internal parts on to which it is flung when the machine is in motion.

Drain plugs are fitted in the bottoms of the gearbox and final drive casings and also in the engine oil sump.

Drain off the engine oil from a new machine after running the first 500 miles, and from the gearbox and final drive casings after the first 1,200 miles. Swill out the final drive casing only with clean petrol. Refit all drain plugs and refill to the correct levels with any one of the grades recommended (see Page 5).

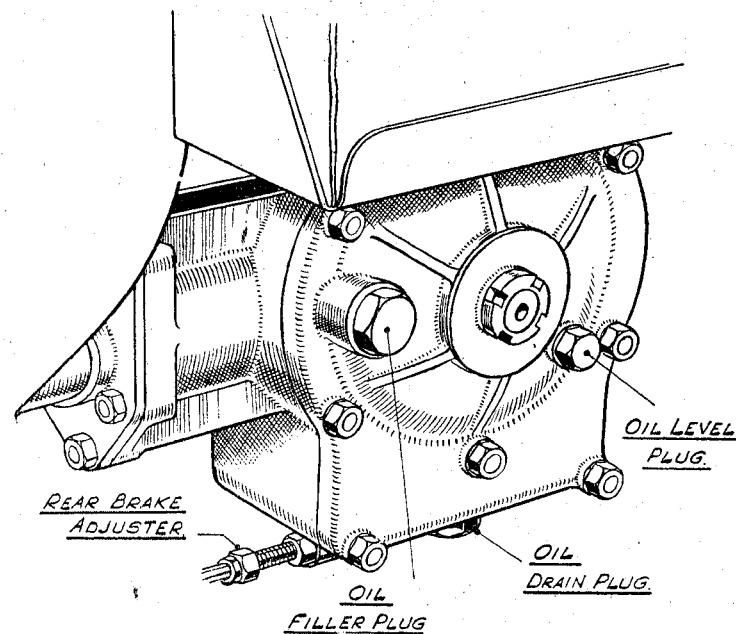

FIG. 2.

**N.B.** Over-filling must be avoided. Subsequent changes of engine oil should be made every 1,200 miles, and the oil in the gearbox and final drive casings after every 3,000 miles running.

The mileages quoted are the maximum distance that should be covered before draining and re-filling the engine oil sump. As clean oil is always beneficial, changes may be made more frequently if desired, and the very slight extra expense will be well repayed, particularly if the machine does a lot of short journeys in between which the engine cools down. Changes at every 800 miles or even less should be considered.

#### Front Fork.

The fork struts have the correct amount of oil in them when the machine is built, and this will last in normal conditions for 20,000 miles running or even longer.

#### Rear Spring Struts.

These may require lubrication about every 5,000 miles and should be removed for the purpose.

If the struts are exceptionally dirty they may be dismantled and cleaned before being re-lubricated. Instructions for dismantling are on page 70.

#### Wheel Hub Bearings.

These are packed on assembly with a high melting point grease and require no further attention for 20,000 miles.

### General Details.

A feature of the machine is the fact that the points needing periodical lubrication have been reduced to the minimum by the extensive use of self-lubricating bushes. It is, however, beneficial, occasionally, to oil the following parts:—

The two brake cable shackle pins (connecting the cables of front and rear brakes to their respective cam levers). The cam lever felts behind the brake cam levers. The rear brake pedal pivot.

The pivots of the brake and clutch control levers on the handlebar.

The twist grip. (Keep oil off the rubber covering when lubricating this).

The linkage from the starting lever to the stand, and the stand pivots.

The exposed parts of the control cables should be smeared with grease to prevent rusting. Occasionally, and if a cable tends to work stiffly, remove the nipple from the handlebar lever, hold the cable upright and pour thin oil (Viscosity SAE10) down the casing. If the time can be spared make up two paper cones, fit one over each casing and tie tightly round it. Support the cables upright and pour oil into the cones over the open ends of the casings and allow to drain down the casings. After about half-an-hour the oil should have penetrated the full length of the cables.

### DISMANTLING MACHINE FOR OVERHAUL. REMOVAL OF THE FRAME.

Obtain a trestle 2-ft. 2-in. wide and 18-in. high, or a stout box of similar proportions. Place the machine across this with the base of the unit resting on the top while the wheels overhang the sides. Disconnect the battery leads and remove the battery from its box below the saddle.

Disconnect the electric leads at the detachable "jacks" or connections below the right hand panel at the top of the legshields. Remove panel with switches by taking out the two fixing screws. The leads are identified by coloured collars, and are marked Red, Green, Black, Brown, Yellow, Blue and White. Unscrew the knurled collar connecting the flexible drive to the speedometer on the left hand side, take out the panel fixing screws and remove the panel.

Take out the  $\frac{1}{2}$ -in. bolts fixing the legshields to the frame (one at each side) and the four small bolts (2 BA) from each side which hold the shields to the frame tube assembly.

There are two at the top and two at the bottom of each shield. Draw off the shields sideways away from the machine.

Slack off the front brake adjuster and remove the cable nipple from the handlebar lever to free the cable. Detach the clutch cable in the same way and without disconnecting any wires remove the dipper and horn switches. Disconnect the two wires from the horn.

Slip out the throttle cable nipple from the carburetter and pull out the cable clear of the frame at the front but do not remove it from the twist grip. Tie the small cable trunnion into the lever on the carburetter to prevent loss. Detach the petrol pipe from the carburetter.

With a tubular spanner remove the two handlebar fixing nuts, take off the washers below them, and lift off the handlebar with headlamp and switch panel etc. Take off the capped nut from the top of the steering column and lift off the steering column cross member.

Support the front wheel and remove the steering column lock nut and dust cover. With a rawhide or other soft-headed hammer tap the steering column downwards, being careful not to damage the thread.

**NOTE.**—Because of material shortages which from time to time have made sufficient supplies of taper roller steering head bearings unobtainable, some machines have, as a matter of expediency, been fitted with cup and cone ball bearings in the steering heads. When the steering column is removed from a machine fitted with these bearings, the balls may drop out, and precautions should be taken to catch them as the column is pulled away. Nineteen  $\frac{1}{4}$ -in. diameter bearing balls are used in each bearing. Thirty-eight in a full set for top and bottom.

When the steering column is free, remove the wheel, mudguard, and fork assembly and stand it upright to prevent the oil running out of the fork struts.

Remove the gear lever knob. Unscrew and remove the lever through the opening in the frame.

Take out the rear wheel spindle, remove the distance piece from between the hollow spindle and the fork end, slack off the rear brake adjuster and remove the wheel.

Support the rear fork assembly and drive casing and remove the two long nuts from the top of the spring units which protrude through the slots in the rear mudguard. Lower the fork assembly gently. Remove the four bolts (two at each side) securing the frame tube assembly to the steering head and the four (also two on each side) which pass through the frame just above the rear of the footboards (Fig. 3). As these are withdrawn, C shaped nut-plates will fall clear from inside the frame. The frame will now lift clear of the engine unit.

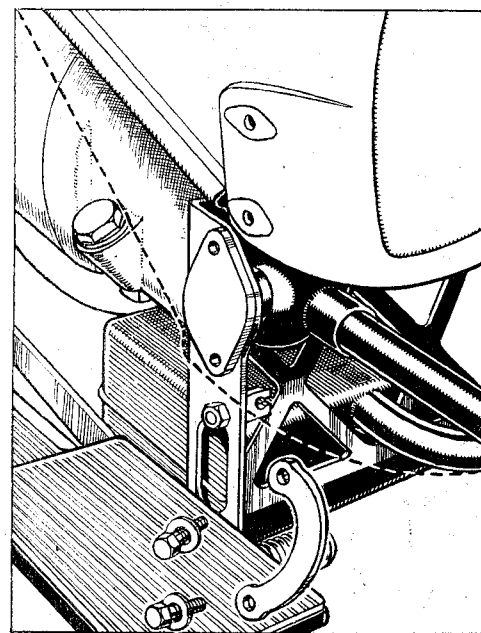

FIG. 3.

Rear part of frame lifted upwards clear of flanged hinge pins. Nut plate and pins shown free.

### SEPARATING THE GEARBOX FROM THE ENGINE UNIT.

Unless any work is to be done to the transmission and the final drive there is no need to remove the rear fork assembly or final drive casing and these may be left in position, attached to the gearbox.

Remove the four bolts and nuts (two at each side) holding the forward ends of the footboards to the brackets at the bottom of the frame tube assembly. Detach both exhaust pipes and the silencer and take off all five nuts and washers from around the gearbox housing (see Fig. 4).

The gearbox can now be withdrawn from the engine. Note that it is located on the clutch housing by two dowels, which must be kept carefully and placed in position when re-assembling.

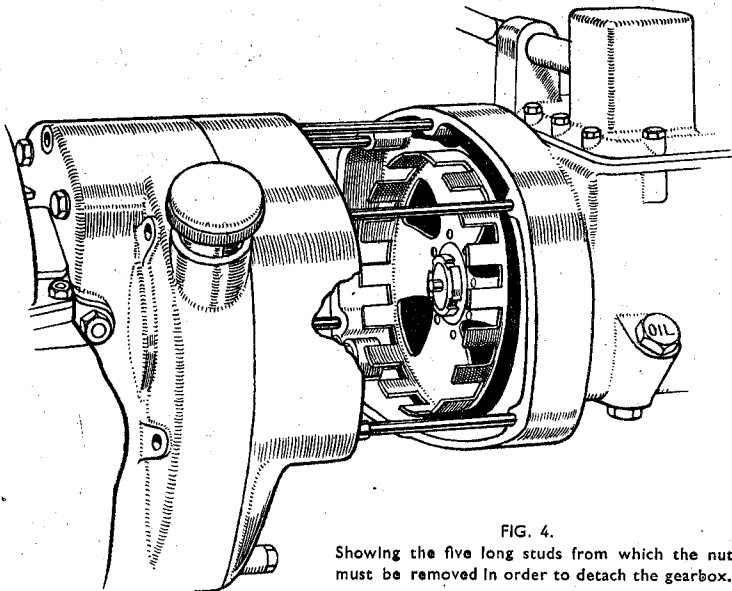

FIG. 4.  
Showing the five long studs from which the nuts must be removed in order to detach the gearbox.

#### REMOVING THE CLUTCH HOUSING FROM THE CRANKCASE.

Having removed the gearbox, the clutch housing may be taken off after removing the two nuts and washers from the studs at the bottom of the housing (see Fig. 5).

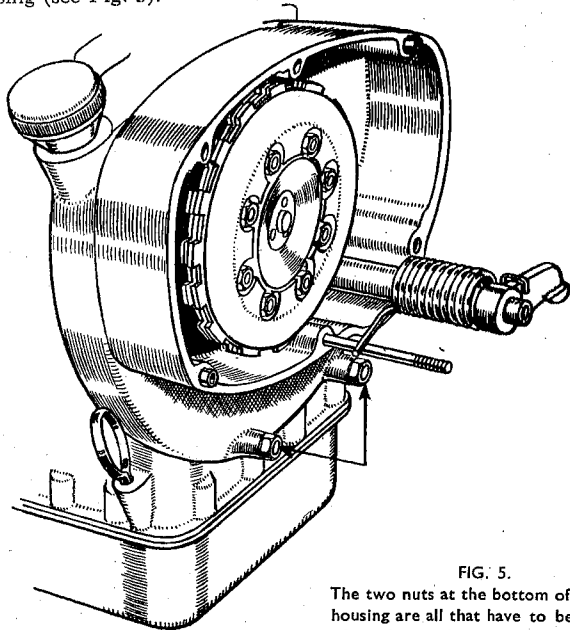

FIG. 5.  
The two nuts at the bottom of the clutch housing are all that have to be removed when the gearbox has been detached.

As the starter spring, which is very strong, is under load it is most important to avoid injuring the hands due to the spring becoming free when the clutch housing comes away. Before fully drawing off the housing therefore, hook the bent-over end of the box spanner LE479 over the spring between the spring and the stud (see Fig. 5) and pull the spring over the stud to free it. The housing may now be pulled right off.

Do not use levers to separate the housing from the crankcase, as this may damage the joint faces and joint washer. Keep the washer carefully for use again.

Two more dowels locate the clutch housing to the crankcase. See that these are kept and used when re-assembling.

#### REMOVING THE REAR FORK AND FINAL DRIVE ASSEMBLY FROM THE GEARBOX.

Slack off the rear brake adjuster and disconnect the cable from the shackle. Unscrew the adjuster right out of the bevel drive casing passing the cable through the slot.

The rear fork pivots on two hinge pins, one at each side at the top of the rear frame cross member. It may be possible to get these out by hand by grasping and turning the flanges to and fro to free them in the cross member—otherwise it will be necessary to tap the flanges round so that they protrude a little beyond the edges of the cross member, and then tap them out of place (see Fig. 6).

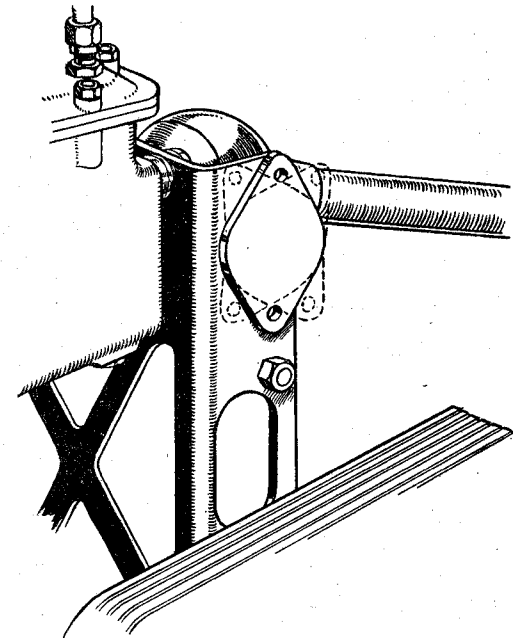

FIG. 6.  
The flanged members at the top of the pressed steel frame at the rear of the unit are the rear fork pivot pins. They may be removed by rocking them backwards and forwards as shown by the dotted lines.

Now stand behind the unit, lift the fork until horizontal, and draw it back and away from the gearbox. When doing so be careful not to damage or lose the two felt washers fitted one at each side of the fork pivots. Another and larger felt ring is fitted at the spherical end of the nearside fork leg. This also must be carefully kept for re-fitting (Fig. 7).

As the fork comes away the Universal Coupling will disengage from the splined secondary shaft.

### REMOVING THE BEVEL DRIVE CASING.

Remove the rear wheel. Disconnect the brake cable from the shackle, screw out the adjuster and pass the cable through the slot in the housing. Remove the rear spring unit from the bevel gear housing. See that the hardened steel bush is put back on the bolt and not lost.

Take off four  $\frac{1}{4}$ -in. nuts and two  $\frac{3}{16}$ -in. nuts and the shakeproof washers from the studs passing through the flange of the rear fork and pull the housing away from the flange. A light tap on the ends of the studs may be needed to free it.

On removing the housing, the propeller shaft, the propeller shaft spring, and the muff coupling, may still be attached to the shaft of the bevel pinion, or the shaft may remain fixed to the universal coupling at the front end. If the former, draw the muff coupling off the splines on the pinion. **Note** that a modification has been made to the muff coupling which is now slightly longer than previously.

When this modification was made it involved altering the fitting of the propeller shaft, which up till then was always put in with the end with the longer splines at the rear. Also the length of the spring was reduced. The spring (LE152) (seven coils) is superseded by spring LE152/2 (five coils) and the longer splined end of the shaft is now fitted at the front with the spring also at that end.

**Do not in any circumstances fit a seven coil spring in place of a five coil one, and note specially when dismantling, which way round the shaft is fitted, and at which end it carries the spring.**

### REFITTING THE BEVEL DRIVE TO THE REAR FORK ASSEMBLY.

Smear the splines at each end of the propeller shaft with graphite grease. Refer to the note in the preceding section on fitting the propeller shaft and refit as directed; sliding the shaft into the splines on the universal joint.

Fit the muff coupling on to the splines of the bevel pinion and offer up the bevel drive casing to the flange on the rear fork, engaging the splines of the muff coupling with those on the propeller shaft. It may be necessary to turn the pinion to and fro to get engagement, when the splines will be felt to locate and slide into place. Refit the shakeproof washers and the nuts to the studs and tighten fully.

Refit the rear brake cable, the rear spring unit and the rear wheel, and adjust the rear brake.

### DISMANTLING THE GEARBOX.

Remove seven  $\frac{3}{16}$ -in. nuts, plain washers, and rubber rings from the studs at the rear of the gearbox securing this to the rear frame cross member (see Fig. 7). Remove the cross member with the stand assembly, brake pedal and footboards attached.

Remove the gearbox top cover after taking off the twelve 2BA nuts and washers around the edge of the cover. Note that two dowels locate the cover and must be preserved and used when re-assembling. They may remain fixed in the cover or be left on their respective studs.

Lift out the speedometer driven gear and push out the clutch thrust pin and the clutch thrust rods from the gearbox primary shaft. Remove the clutch lever from the rear of the gearbox.

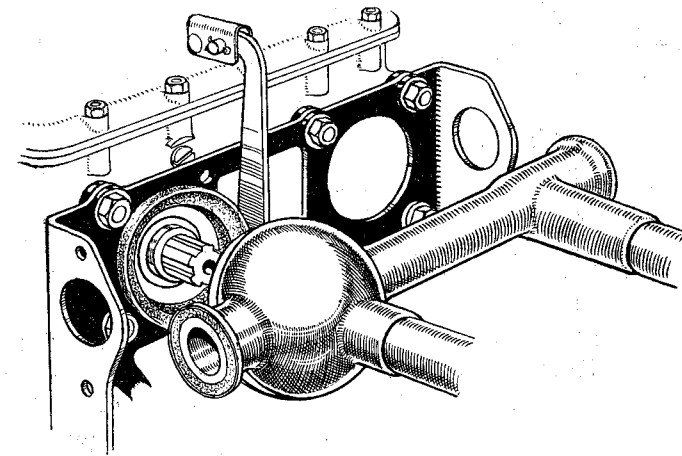

FIG. 7.

When removing the rear fork, take care of the felt washers at each pivotal point and the large one at the spherical end.

**NOTE.**—Earlier machines have two  $\frac{1}{4}$ -in. diameter thrust rods only (Fig. 8). Later models have two  $\frac{1}{4}$ -in. rods of unequal length and a short, smaller diameter pin working in a brass bush at the front end of the primary gear shaft. This does not complicate assembly in any way but the illustrations should be referred to for the arrangement (Fig. 9). The longer of the  $\frac{1}{4}$ -in. diameter thrust rods is supplied in different lengths to take up play in the operating mechanism should this be required, and should the eccentric bolt adjustment of the clutch lever be insufficient.

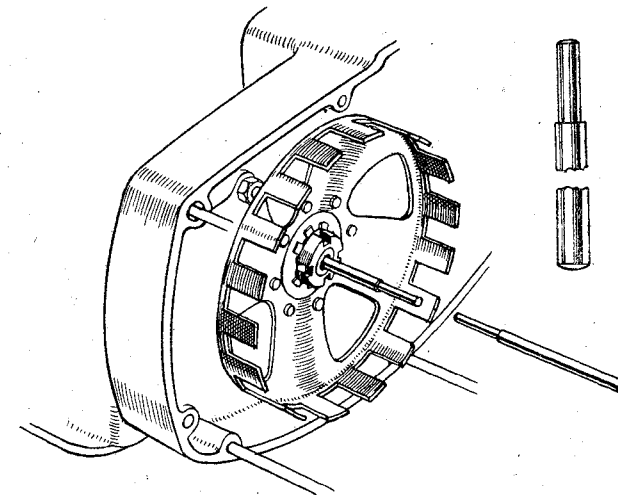

FIG. 8.

Arrangement of Thrust Rods when two are used.



Set the gearbox with the starting handle on the left so that you face the clutch bell (LAS29). To prevent the shaft turning whilst undoing the primary shaft lock ring (LE29) engage two gears at once by moving the selector slides one after the other to the rear (away from you) so that the plungers in the slides are both engaged in the third groove of the selector bar.

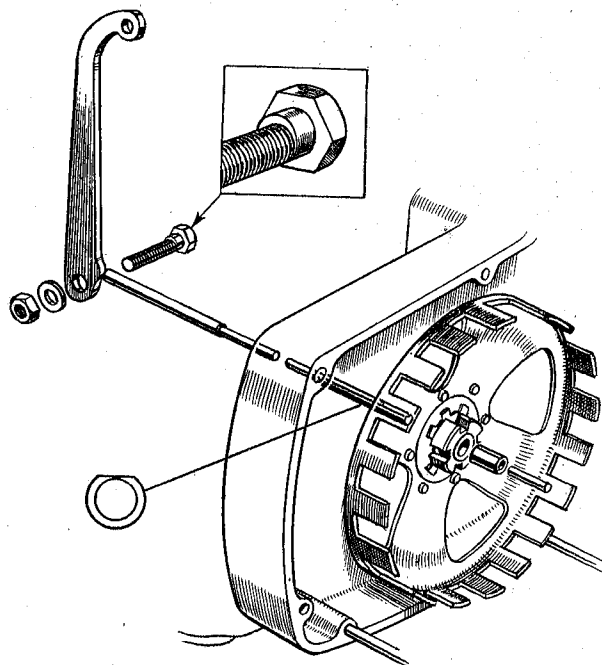

FIG. 9.

Arrangement of Thrust Rods and Thrust Pin with later type Bushed Primary Gear Shaft.  
Inset shows Eccentric Lever Adjusting Pin.

The primary shaft must be turned slowly whilst moving the second slide to allow the gears to engage.

With two gears engaged and the primary shaft thus prevented from turning, bend down the tab of the lock washer and remove the lock ring with spanner LET780 and take off the lock washer.

Draw the clutch bell assembly off the primary shaft and take off the five  $\frac{1}{4}$ -in. and  $\frac{1}{8}$ -in. nuts and washers securing the gearbox end cover. Tap out the selector bar from the end cover, taking care to catch the two plungers and springs from the selector slides and which may fall into the gearbox as the selector bar comes out.

To remove the end cover and gearshafts, etc., heat up the rear end of the gearbox housing around the bearing housings to not more than 100° centigrade or preferably stand the housing in boiling water, and when hot tap the cover forward from inside the gearbox with a soft metal or wood punch passed through the top of the housing. The cover, shafts and gears will all come away together. The secondary gearshaft ballrace will probably come away with the shaft as it is held by the distance collar behind it.

Note that two dowels are used to locate the end cover and may come off with it or remain on their respective studs.

Be very careful when heating aluminium alloy housings to free bearings etc., that the temperature of 100° centigrade is not exceeded, as this causes harm to the alloy. For this reason immersion in boiling water is preferable to other methods of heating.

The end cover may be removed from the secondary shaft by the same means. The ballraces may be jarred out of their housings when the housing is hot.

The secondary low gear wheel will pull off the shaft. The speedometer driving gear is not readily removable from the shaft and is almost certain to be damaged and rendered useless if an attempt is made to get it off. There is no need to take it off in the ordinary course of events, but if damaged or excessively worn it must be levered off the shaft.

To remove the primary low gear wheel support the primary top gear wheel assembly on a suitable bush or over two stout steel plates upon a press and with the splined end of the shaft uppermost. Press the shaft out of the gear at the same time removing the distance collar.

A cork washer is fitted behind the primary shaft ballrace in the housing and this should be renewed if the ballrace is replaced.

The oil seals in the cover and housing may be removed if in need of replacement and new ones fitted, using the special tool (Fig. 10) for fitting the cover oil seal, and tool LET786 (Fig. 11) to fit the one in the housing.

The oil seals in the cover and housing may be removed if in need of replacement and new ones fitted, using the special tool (Fig. 10) for fitting the cover oil seal, and tool LET786 (Fig. 11) to fit the one in the housing.

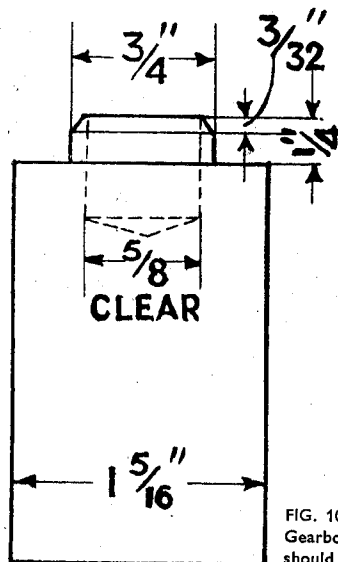

FIG. 10.

Gearbox end Cover Oil Seal should be fitted by means of a Tool such as the one shown.

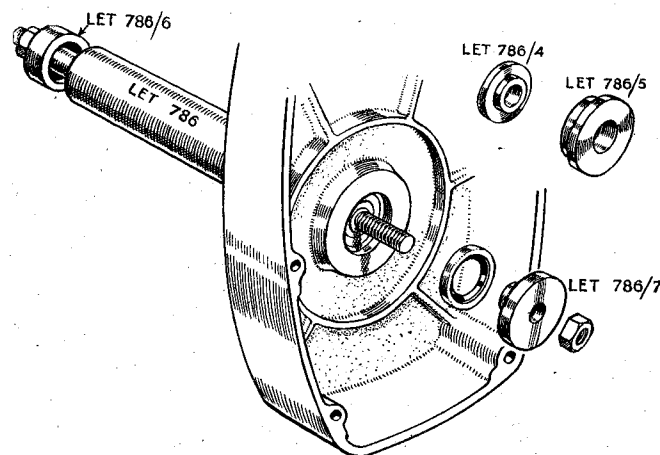

FIG. 11. Service Tool No. LET 786. For fitting oil seals.

With Collars extra, LET 786/4, LET 786/5, LET 786/6 and LET 786/7.

As it is so easily made the tool shown in Fig. 10 is not listed as a special Service Tool, but the details given show clearly what is needed.

### STRIPPING AND RE-ASSEMBLING THE GEARBOX TOP COVER ASSEMBLY.

Although directions for this work are given below it is very unlikely that the cover assembly will ever need dismantling during the life of the machine. The parts do not suffer noticeable wear even after years of use and thus should not normally need replacing.

Remove the interlock gate (secured to the cover by two 2BA bolts) by cutting the locking wire and taking out the bolts (Fig. 12). Slacken the nut on the selector finger bolt and lever the finger off the selector shaft. Pull out the shaft with the gear lever end. To remove the ball cage and bearing balls, prise out the washer and take out the felt washer, when the cage may be pulled out.

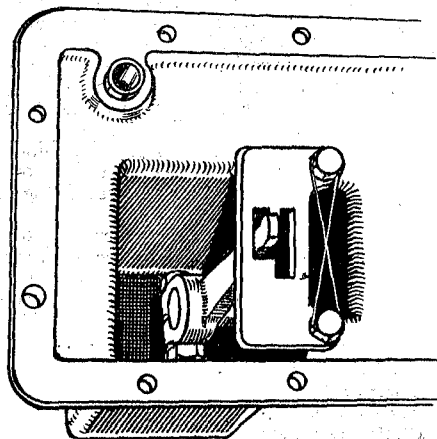

FIG. 12.

How the Selector Shaft Finger, the Interlock Gate and Locking Wire should be fitted.

To reassemble, stick the twelve bearing balls into the holes in the cage with grease, slide the cup washer and felt along the selector shaft in that order with the plain side of the cup washer towards the gear lever end. Slide the cage and bearings over the selector shaft about three-quarters of the length of the cage, leaving the inner end with the bearings just protruding beyond the splined end of the shaft. The splines must not at this stage be pushed up underneath the bearings as this will prevent the cage going into place in the tube.

Push the cage and lever together into the tube and when the end of the cage is flush with the tube, push the selector shaft right through and fit the felt and cup washer into place and tap the washer home.

Fit the selector shaft finger, making certain that it is fitted on the correct splines to set the gear lever end in the position as shown in Fig. 13 when the finger is in the neutral position shown in Fig. 12.

It should be noted that the proper working depends upon the absolutely correct fit of the selector shaft in the bearings and the shafts are selectively assembled in production. Therefore should a new shaft be required the original one should be measured with a micrometer and the exact diameter quoted when ordering a new one.

### RE-ASSEMBLING THE GEARBOX.

Heat the housing sufficiently to expand the bores to receive the two ball races. Do not overheat as this will distort the housing.

Fit a new cork washer into the primary shaft ballrace housing up against the housing face. Drop the ballraces into their housings and tap them home, using a bar which will locate on their outer rings. Fit the drain plug and the bottom bearing for the speedometer driven spindle. Tap in the secondary shaft oil seal with the special tool (Fig. 10).

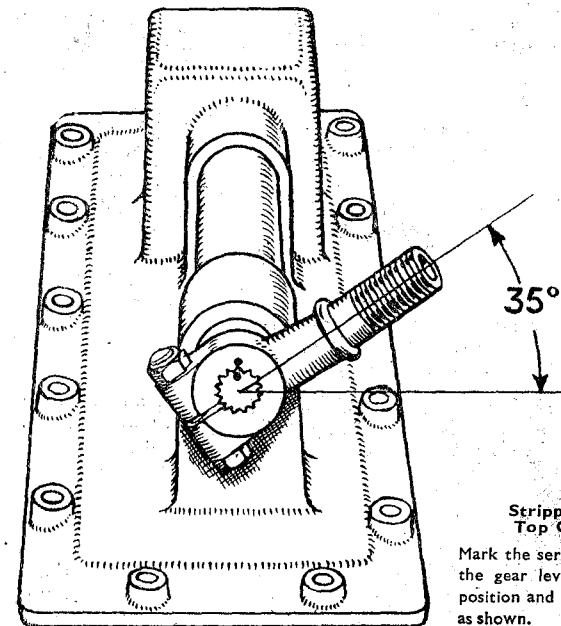

FIG. 13.

### Stripping and Refitting Top Cover Assembly

Mark the serrations before detaching the gear lever. Fit back into same position and at an angle of 35 degrees as shown.

In the unlikely event of the speedometer driving gear needing replacement, the old gear must be levered off the shaft and will unavoidably be damaged in the process, thus it should not be disturbed unless in need of renewal. Should a new one be fitted be sure that the recessed end fits over the shaft first against the face of the second gear.

Fit the secondary low gear wheel over the plain ground end of the shaft with the driving dogs on the gear facing the dogs on the shaft, and put the shaft into the gearbox housing through the opening in the front, pushing the shaft through the ballrace. Fit the distance collar over the splines and tap firmly home.

Over the splined end of the primary gear shaft fit the top gear wheel locating the driving dogs with those on the shaft (Fig. 14). Next fit the primary low gear, making sure that the recessed face fits against the shoulder at the end of the splined section of the shaft, and press home, using a suitable bush to support the shaft. Next fit the distance collar, being careful not to confuse this with the oil seal collar. The latter has a smoothly ground finish on its outside diameter, but the distance collar is ground on the end faces only. This collar may need pressing into position. Slide the primary middle gear wheel on to the other end of the shaft and enter the shaft into position in the gearbox through the top opening. Mesh the gears, and whilst holding the middle gear meshed with the dogs on the shaft push the rear end of the shaft into the ballrace in the gearbox housing. Tap the shaft firmly home.

See that the two ballraces are fitted to the end cover, and if a new joint washer is needed fit it over the studs and follow it with the cover. Fit the two dowels into the recesses and put on the washers and nuts and tighten up.

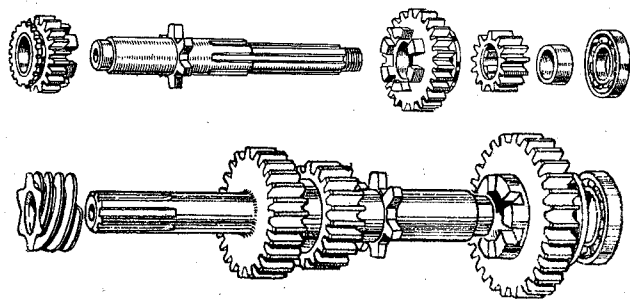

FIG. 14.  
Arrangement of Gearbox Shafts and Gears.  
Top, Primary Shaft.  
Bottom, Secondary Shaft.

Fit the primary shaft oil seal and tap firmly into place into the end cover. The flat top of the oil seal must be flush with the bottom of the groove or notch which is cut in the cover. Fit the oil seal collar. Do not tap this too hard against the bearing or the bearing may move in the cover.

#### RE-FITTING THE SELECTOR SLIDES.

First fit into each slide the plunger spring and plunger and hold them in place with two special clips as shown in Fig. 15. These clips are not supplied as Service Tools as they are so easily made from ordinary steel strip. The inset to the illustration gives full details and dimensions.

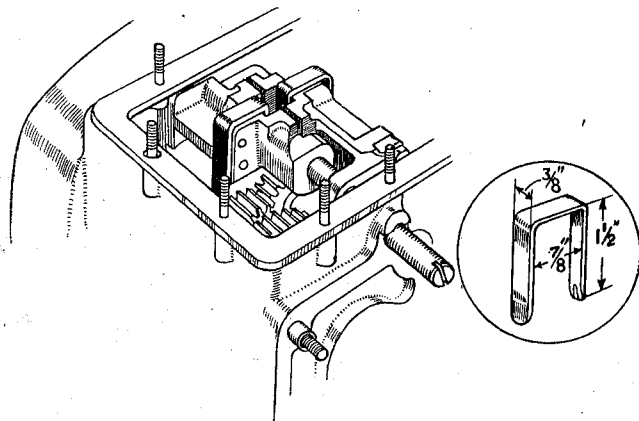

FIG. 15.  
A tool like the one shown should be used to hold back the plunger and spring in the selector slides while assembling.

Fit the forks into the grooves in their respective gears, the double fork slide in the primary gear shaft gears, and the single fork slide in the gear on the secondary shaft. Hold them in alignment and slide the selector bar from the rear of the gearbox through the holes in the selector slides. When the bar is in such a position that it will retain the plungers, the retaining clips may be withdrawn. Push the selector bar on through the holes in the forward ends of the selector slides into the hole in the front cover plate. Fit the washer and nut to the end of the bar and tighten the nut.

#### RE-ASSEMBLING THE CLUTCH BELL TO PRIMARY SHAFT.

The clutch bell must be fitted to the primary shaft before fitting the top cover. Engage two gears at once to lock the gearbox, as previously described, and fit the lockwasher and the primary shaft nut and tighten fully, using Service Tool LET 780 (Fig. 16). Do not force and over-tighten the nut, and do not omit to bend back the tabs of the lockwasher into the clutch bell and the appropriate notch in the lock ring.

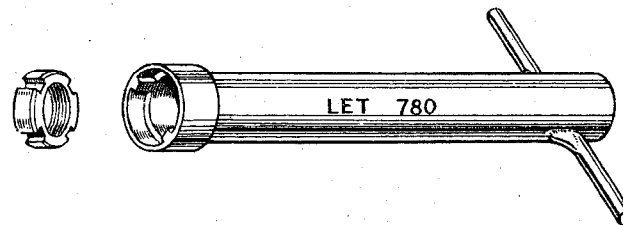

FIG. 16.  
Service Tool No. LET 780. Lock Ring Tube Spanner.

#### RE-FITTING THE GEARBOX TOP COVER ASSEMBLY.

Return both selector slides to neutral position (Fig. 15): the spring loaded plungers engaged in the central groove of the selector bar. Refit the speedometer driven gear locating it in the bearing in the bottom of the housing, and engaging the teeth with the gear on the secondary shaft. See that the joint washer is in place and in good order.

Place the top cover in position, making sure that the selector finger is engaged in the milled slots in the tops of the selector slides and the upper end of the speedometer driven spindle through the bearing in the top cover. Fit the 12 washers and nuts and tighten evenly. Push the two clutch thrust rods into the bore of the primary shaft, together with the thrust pin at the front end and fit the clutch lever. (See Note Page 13 and Figs. 8 and 9).

Any wear on the thrust operating mechanism may be taken up by adjusting the eccentric pin securing the lever to the gearbox. This adjustment may also need alteration if new thrust rods are fitted. (See Fig. 9).

#### DISMANTLING THE CLUTCH HOUSING ASSEMBLY AND CLUTCH.

To take apart the clutch a suitable hand press is needed. Place the clutch housing assembly on the base of the press and bring down the ram of the press on the centre button of the pressure plate and depress until the pressure of the clutch springs is taken off the fixed plate. Hold the pressure plate in this position and remove the eight 2 BA nuts and washers from the studs. Release the press gradually until the clutch

springs are fully extended. Remove the fixed plate, Ferodo, floating plate, second Ferodo, and pressure plate in that order. Pull out the eight springs and spring cups from the driving plate (Fig. 17).

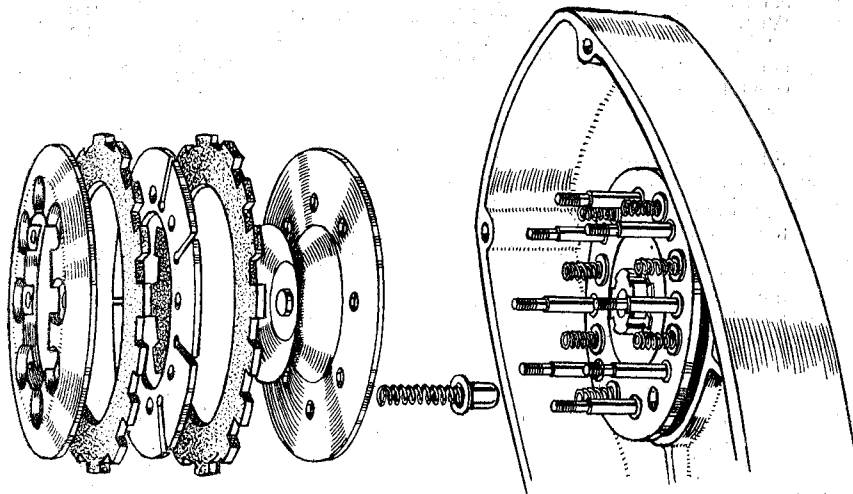

FIG. 17. Positions of the various members of the clutch assembly.

#### SPECIAL NOTE.

We sometimes receive complaints that the slotted centre clutch plate is not flat and that the main contact with the Ferodos, has been on parts of the segments only—the leading portions on one side and the trailing portions on the other—giving rise to the belief that the plate is faulty and badly made.

The centre plates for some time now have been intentionally set in this way during manufacture with the object of providing a cushioning effect and making the clutch engage more smoothly, and as the full pressure of the clutch springs is exerted on engagement the centre plate tends to flatten out.

Experience has shown that it is advisable always to fit a set of new clutch springs on re-assembling the clutch after overhaul.

#### REMOVING CLUTCH DRIVING PLATE FROM REDUCTION GEAR SHAFT.

The reduction gear shaft must be held securely whilst the lock ring is removed. This may be done either by holding the large reduction gear in a vice, using lead clamps to avoid damaging the teeth, or by placing the clutch housing assembly back into place on the crankcase, and engaging the gear with its mating gear on the crankshaft. In either case bend back the tab of the lockwasher from the locking ring, and unscrew the latter off the shaft with the locking ring spanner LET780 (Fig. 16). Remove the tab washer and withdraw the clutch driving plate.

The reduction gear shaft assembly may now be withdrawn from its plain bronze bearing in the clutch housing. Pull off the oil seal collar and the bearing collar. The starter pinion will then come away.

If there has been a leakage of oil into the clutch housing a new oil seal should be fitted, otherwise the oil seal should not be disturbed. If it is removed from its housing a new one is essential.

#### REPLACING THE REDUCTION GEAR SHAFT OIL SEAL (LE431).

Place the new oil seal on the special tool (LET786) and push this through the bearing. Screw the nut on to the end of the tool and continue until the oil seal has been drawn into place (Fig. 11).

#### FITTING THE REDUCTION GEAR SHAFT ASSEMBLY AND CLUTCH.

Fit the starter pinion on to the shaft (See Fig. 18), spring the pawls apart and push the pinion right home. Press on the bearing collar with the flange towards the pinion. Push the shaft through the bearing and push the oil seal collar into place through the oil seal.

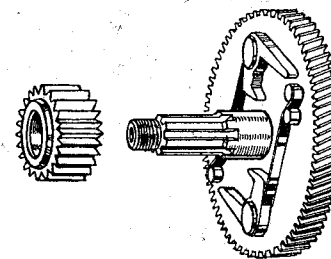

FIG. 18.

Showing the assembly of starter springs and reduction gear on two types of unit.

Replace the clutch driving plate on to the splined end of the reduction gear shaft, replace the tab washer and knock back the tab of the washer into its position in the plate. Refit and tighten the lock ring, holding the gear firmly meanwhile as described when dismantling. Bend back a tab of the lockwasher into a notch in the lock ring.

Place the eight spring cups in position in the driving plate and fit the new springs into them. It is as well to check their free lengths and verify that they are of equal length before fitting. Put the pressure plate over the studs, checking that it works freely. Now put on the first Ferodo plate, the floating plate, the second Ferodo plate and finally the fixed plate (Fig. 17).

**NOTE.** The fixed plate is an iron casting and is marked with red paint. This mark must correspond with a similar mark on the driving plate and the clutch should be assembled with the plates in this position.

Having replaced all the clutch plates, place the whole clutch housing assembly on the base of a hand press. Depress the clutch pressure plate against the spring pressure. Locate the fixed plate on the eight studs of the driving plate. Replace the eight washers and nuts and tighten. Release the pressure plate.

#### LINING UP THE CLUTCH PLATES WITH SERVICE TOOL LET791.

The clutch plates have now to be lined up by means of the clutch alignment tool LET791. This is placed over the clutch and engaged with the projections on the Ferodo plate (Fig. 19). The pressure plate is then depressed again on the press to free the clutch plates. The alignment tool is then pushed home fully so as to locate on the outer edge of the fixed plate. Having lined up the Ferodo plates in this way release the pressure and pull the tool away.

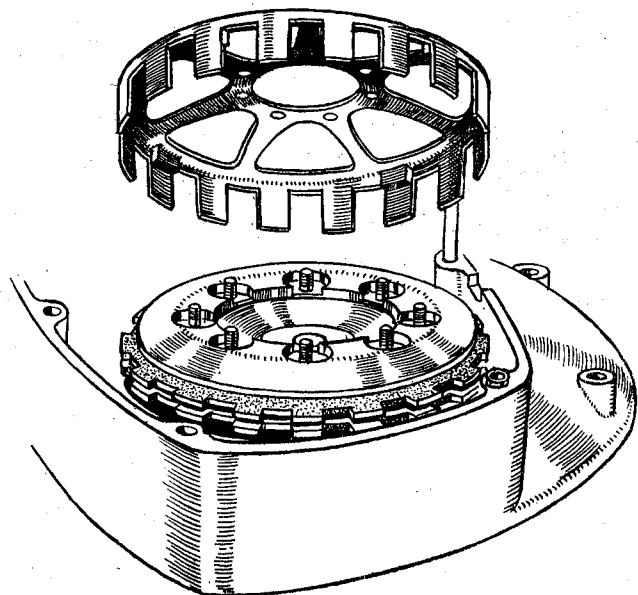

FIG. 19. Clutch alignment tool LET 791 should be used to line up the clutch plates.

### REMOVING THE STARTER SHAFT AND STARTER SEGMENT.

Hold the lever end of the starter shaft firmly in a vice, using protective clamps over the jaws to avoid damage to the shaft. Bend back the tongue of the tab washer from the lock ring, and remove the locking ring with spanner LET780 (Fig. 16). Take off the tab washer and draw the starter segment off the shaft. Remove the shaft from the vice and withdraw it from the bearing in the clutch housing. Remove the starter spring.

If the bearing needs renewing, it may be pressed out of position and a new one fitted. The oil seal will have to be removed in the process and must be replaced with a new one. Do not attempt to use the old one again.

### FITTING THE STARTER SHAFT OIL SEAL.

Place the new oil seal on to the appropriate end of the double-ended oil seal replacement tool LET786, place the tool in position in the starter shaft bearing, fit and tighten the tool nut, drawing the oil seal into its correct position. (Fig. 11).

### REFITTING THE STARTER SEGMENT ASSEMBLY ON TO THE STARTER SHAFT.

The starter segment must be fitted so that it is set correctly in relation to the starter shaft.

With the shaft in position in the clutch housing and the return spring fitted, hold the clutch housing with the splined end of the shaft pointing upwards.

Fit the starter segment on to the splines so that the straight edge of the segment is at right angles to the lever at the other end of the shaft and remote from the starter pinion, *i.e.*, with the housing held as previously described, the straight edge of the segment will be on your left.

Hold the lever end of the shaft in a vice, not omitting to protect it with soft clamps, replace the tab washer, fit and tighten the lock ring with spanner LET780 (Fig. 16) and bend a tongue of the tab washer into one of the recesses in the lock ring.

### VALVE TAPPET ADJUSTMENT.

The tappets seldom need re-adjustment as the clearances tend to remain constant for many thousand miles running. If the engine is running satisfactorily and there is no excessive noise from the tappets it may be taken that re-adjustment is unnecessary.

Re-adjustment is only needed in normal circumstances, after the valves have been refaced and ground in.

To reach the tappets the induction pipe has to be removed. Turn off the petrol, disconnect the fuel pipe from the carburetter and slip the control cable nipple from the carburetter. Take off the air cleaner connecting sleeve. Take off the nuts and washers from the induction pipe studs on the cylinders, and remove the pipe and carburetter. Take care not to drop and lose the control cable trunnion from the lever on the carburetter.

Take off the eight nuts and washers from the tappet cover studs and remove the covers. If this is done carefully the joint washers may be undamaged and if so should be kept aside for re-fitting.

When re-adjusting the clearances the crankshaft must be set so that the position of the cylinder being dealt with is at top dead centre of compression stroke. To find this position turn the crankshaft forward slowly and watch the movement of the valves and tappets through one of the openings in the top of the crankcase. Note that as the exhaust valve reaches the closed position the inlet valve alongside begins to open. There is a short period when both valves are slightly open, and at this point the piston on the opposite cylinder will be at top dead centre of compression stroke.

To prevent the tappets turning during adjustment place the wedge tool (LE518) in position between the milled flats on the tappets (See Fig. 20).

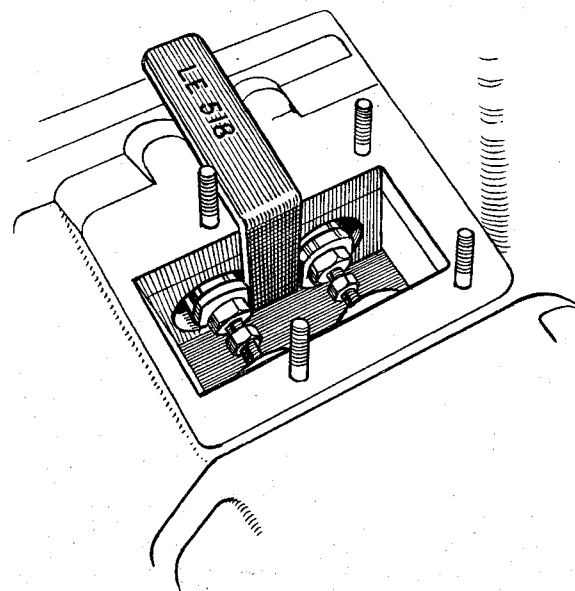

FIG. 20.

Holding Tappets during Adjustment. Tool LE 518 in use.

Place one spanner on the lock nut, and the other on the tappet adjuster head and "take the strain" on this second spanner whilst loosening the lock nut. Re-adjust the clearances to allow .004 inch (.1 m/m) on the inlet and .006 inch (.15 m/m) on the exhaust. To increase clearance screw the adjuster into the tappet; movement in the opposite direction will decrease it. Reset as required and check the setting with a "feeler" clearance gauge of the appropriate thickness. When set correctly hold the adjuster firmly with one spanner and with a second spanner re-tighten the lock nut securely. Recheck the clearance, as the tightening of the lock nut may cause a slight alteration. If needed reset.

**Note that clearances must be checked and adjusted only when the engine is cold.**

Refit the tappet covers, using new joint washers if the old ones were damaged during removal. Put back the washers and nuts and tighten. Refit the induction pipe and carburetter, using new induction joint washers if needed. Refit the washers and nuts and tighten. Replace the air cleaner sleeve, and connect up the petrol pipe, and the control cable to the carburetter.

### DECARBONISING AND GRINDING IN VALVES.

A deposit of carbon will form on the piston heads, valve heads, and combustion chamber after some thousands of miles' running, making it necessary for it to be cleaned out. At the same time the valves usually require regrinding into the seatings in the cylinders. No hard and fast rule can be laid down as to when this decarbonising will be required, but it is safe to assume that as long as the engine is running well and there is no definite evidence such as overheating, or serious loss of power, no attention is needed, it is best to leave well alone and not needlessly dismantle the cylinders.

### REMOVING THE CYLINDER HEADS.

Take out the drain plugs from the heads and drain off the water. Disconnect the high tension leads from the sparking plugs and remove the plugs. Slacken off each of the cylinder head nuts (six on each head) a half turn at a time in the order shown in Fig. 24 until they are all loose. Remove them and the washers below them and pull the heads off the studs. If the heads are stuck and do not move easily, tap each one carefully with a rawhide mallet or piece of hard wood to free them. Do not in any circumstances attempt to prise them off by the insertion of levers or screwdrivers between the joint faces, as this will certainly damage the gaskets and may even harm the cylinders or heads.

Carefully pull off the gaskets over the studs and preserve for re-fitting.

It is more convenient to clear the carbon deposit from the piston crowns and valve heads, etc. before taking off the cylinders. Clean the combustion spaces in the heads. When scraping the carbon from the heads and pistons do not use a hard tool as this will cut the aluminium. A piece of strip brass, or copper, filed to an edge will do well and will not scratch and damage the surfaces, which must be left as smooth as possible. **Note specially never to clean the piston crowns with emery cloth or anything of a similarly abrasive nature.** The abrasive is certain to get into the engine and cause serious harm. When clean, put the heads aside until ready to refit them.

### REMOVING THE CYLINDERS.

Note the positions of the four water connections, loosen the hose clips and detach the hoses from the cylinders. Loosen and remove the four exhaust pipe flange nuts and pull the flanges away from the cylinders. Pull the exhaust pipes forward, after loosening the silencer clip bolts, and take them right off. If the pipes are tight, work them about a little to turn them in the silencer. This should free them.

Remove the flange joint washers carefully and keep aside for use when re-assembling. These are made of special material and if they have to be renewed only genuine joint washers must be used. Other material is unsuitable.

Remove the induction pipe and carburetter as described on Page 23. Loosen and take off all the cylinder base nuts and the washers (ten of each in all) and pull off the cylinders, being careful to pull straight and exactly in line with the pistons to prevent distorting the connecting rods. As each cylinder comes clear of the piston, put one hand under the piston to stop it dropping against the crankcase. When the cylinder is right off lower the piston carefully against the crankcase.

### REMOVING VALVES AND SPRINGS AND CLEANING VALVES.

Compress the valve springs and take out the split cotters. The screw-down compressor (LET794) is needed for this work (Fig. 21).

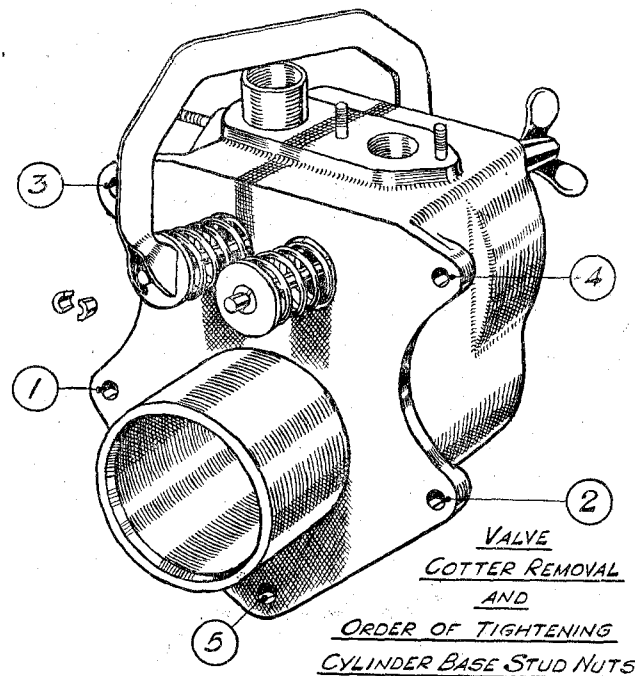

FIG. 21.

Fit the compressor in place with the cup end over the valve spring collar and screw down the compressor screw against the valve head. Keep screwing down until the collar is drawn up and the spring compressed sufficiently to expose the split cotter and allow it to be picked out.

Release the spring by unscrewing the compressor screw, take away the compressor and remove the valve spring, then pull the valve out of the guide. Deal with the other three valves in the same way but keep each valve, as it is removed, in a known position on the work bench so that it may be ground in to the seating from which it was taken, and be re-fitted in that seating when re-assembling. The valves are all interchangeable but after they have been in use it is best to keep them working in their own places and not to change them about.

Clean the valve heads, and the radii underneath the heads; being careful not to damage or reduce in diameter the upper parts of the stems which bear in the valve guides. The seats may be refaced in a refacing machine if one is available, but do not grind any more material from the valves than is absolutely necessary to remove the pitting.

The valve seat angle is 45 degrees. If the pitting is very deep or the valves are otherwise in a bad state, refacing may reduce the valve head diameter to such an extent that the valves seat too low in the seatings in the cylinders, or the outer edge of the valve heads above the seatings may be made too thin. In such circumstances new valves are required.

The object of having valves refaced before grinding them in is to avoid wearing the seatings in the cylinders more than is essential to obtain good gas-tight fitting, as, of course, although valves are not expensive to renew, the cost of new cylinders, in which the seatings are not replaceable, would be considerable.

The "leaded" fuels in general use nowadays form a hard deposit on the exhaust valves and this must be cleaned off before re-fitting. Refacing by grinding on a valve refacer will be needed and the remainder of the scale can be cleaned off the head and radius by running the valve in a lathe or drilling machine and rubbing off the scale with a piece of carborundum held against the valve.

A valve seating cutter LET686 is available for trueing up the seatings in the cylinders; work which may become necessary after very large mileages have been run (Fig. 22). Special care is needed when re-cutting the seats to remove as little metal as possible.



FIG. 22. Service Tool No. LET 686. Valve Seat Cutting Tool.

### GRINDING IN THE VALVES.

Clean all carbon from the valve ports and from around the edges of the valve seatings, taking care not to damage the seatings or guides.

The grinding in process consists of coating the valve seating very lightly with an abrasive valve grinding paste, usually obtainable from any Accessory dealer in tins containing two grades. A very little of the finer grade should be smeared over the seating on the valve and the valve pushed into place in the guide. The valve is then partly rotated, against the cylinder seating by means of the valve lapping tool LET687 (Fig. 23).

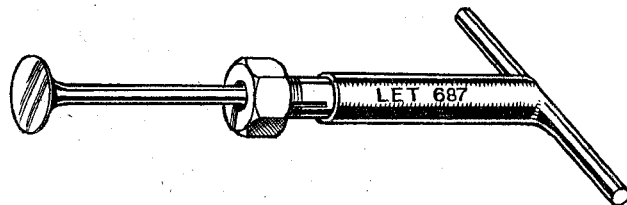

FIG. 23. The Valve Lapping Tool No. LET 687 (with valve).

After every few movements of the valve the head should be raised from contact with the cylinder seating, turned about half way round, and then brought back into contact and the grinding continued until an even grey matt seatings is obtained on both seatings.

It is in the lifting of the valve, and the constant changing of its position relative to the cylinder that the secret of good valve grinding lies. Never use a grinding paste of coarser grade than is needed to grind the seatings clear of pits, etc., and never fully rotate the valves against the cylinder seatings when grinding in. This causes the formation of concentric rings on the seatings and thus must be avoided.

Frequently during the grinding in remove the valves for inspection, wash them in clean petrol and wipe the seatings in the cylinders clear of abrasive. Stop grinding as soon as an even seating is obtained.

A polished surface must not be expected and is quite unnecessary.

Withdraw each valve as it is finished and wash carefully in clean petrol or paraffin. Dry off with clean rag. Also clean the seatings in the cylinders and the surrounding valve ports with rag moistened in petrol or paraffin. Do not wash out the valve ports as this is likely to carry abrasive matter into the guides, or other working parts. Wipe dry with clean rag. When satisfied that all trace of abrasive has been removed the valves may be refitted.

### RE-FITTING VALVES AND SPRINGS.

Select the correct valve for the port in which it is to be fitted, smear the stem lightly with oil and insert the stem in the guide. Place the valve spring and spring collar in position and compress the spring using the tool (LET794) as previously described (Fig. 21). When enough of the cotter groove at the end of the valve stem has been exposed to allow the cotter to be fitted, insert the two halves around the stem (small ends toward the valve head), and release the spring gradually, holding the cotter in place until held by the valve spring collar.

Make sure that both halves are seated properly before dealing with the next valve.

### RE-FITTING THE CYLINDERS.

See that the cylinder base washers are in place and in good order. If damaged fit new ones.

Wipe out the cylinder bore with clean rag, making sure that no lint or fluff adheres to the cylinder wall. Smear clean oil lightly over the bore. Set the piston rings in the grooves so that the gaps are not in line—space them as nearly as possible at 120° to one another. The actual positions of the gaps are not important provided that they are equally spaced from each other.

Support the piston in the right hand, and whilst sliding the cylinder over the piston, compress each ring in turn in the groove to enter it in the cylinder. The mouth of the cylinder is chamfered to assist the entry of the rings. Push the cylinder on over the studs until they project through the base flange far enough to allow the washers to be fitted and nuts to be started on the threads. The nuts can now be run down the threads as the cylinder is pushed home. Tighten the nuts in the correct order (Fig. 21) a little at a time until fully tight.

The tappets must now be re-adjusted as described on Page 24, where the clearances are given.

### RE-FITTING INDUCTION AND EXHAUST PIPES, AND WATER CONNECTIONS.

See that the flange joint washers are in place, and renew any which are damaged. Replace the induction pipe as described on Page 24 and fit the air filter sleeve.

Connect the top and bottom water connections to the cylinders and tighten the hose clips.

Slide the exhaust pipe flanges up towards the cylinder ends of the pipes, and fit the other ends of the pipes into the silencer, pushing them in until the flanged ends fit closely against the flange joint washers on the cylinders. Push the flanges over the studs, replace the washers and nuts, and tighten up. Tighten the silencer clip bolts.

### RE-FITTING THE CYLINDER HEADS.

See that the gaskets are in good condition and fit to the cylinders. Use new ones if needed. Note that as the valves are slightly offset from the centre line of the cylinder there is a right and a wrong way of fitting. The gasket is fitted correctly when the inner edges of the gasket are approximately equally spaced from the valve heads. Trial of the gasket in the two ways will show the difference, as, incorrectly spaced, the edge of the gasket will be about  $\frac{3}{8}$ -in. closer to one valve than the corresponding edge is to the other. Smear each side of the gasket lightly with grease.

Keep the gasket parallel to the joint face when pushing it over the studs so that it is not distorted by tilting.

Place the cylinder head in position and push it down evenly against the gasket. Fit the washers and nuts and run the nuts along the threads up to the washers. Tighten them each a quarter turn at a time until they are fully tight in the order shown (Fig. 24).

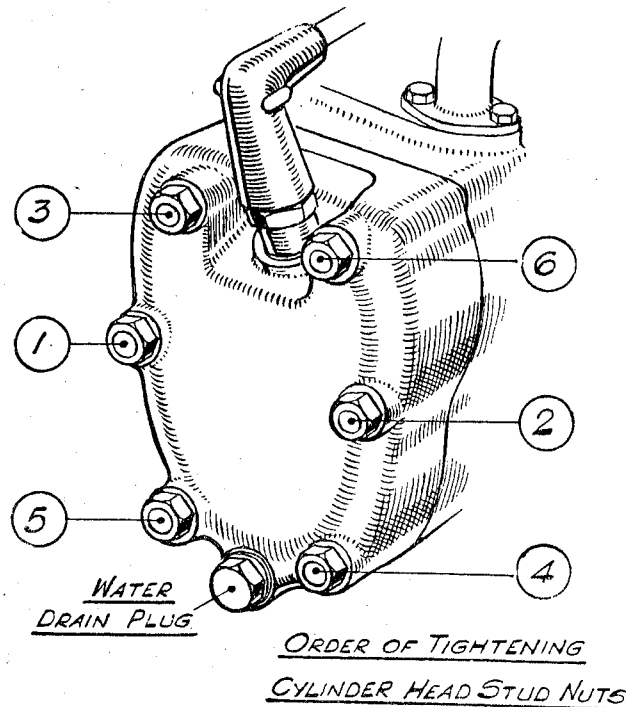

FIG. 24.

Clean and adjust the sparking plugs (see Page 84) and refit, tightening down fully. Attach the high tension cables. Fit the cylinder head drain plugs.

Note specially that if new head gaskets are fitted they need "cooking" as follows :—

After fitting the heads and putting back the drain plugs pour in only about a pint of water to the radiator. Start the engine and run it until the water boils. Stop the engine and retighten all the head nuts in the correct order. When the water has cooled off a little top up the radiator to the correct level. Refill the radiator, using "soft" water. Check for water leakages.

There should be no leaks if the hoses and clips are in good order, and if each hose is equally spaced over the gaps between the radiator nozzles and the water pipes and cylinder nozzles.

### REMOVING FRAME TUBE ASSEMBLY AND RADIATOR FROM CRANKCASE ASSEMBLY.

It is assumed that the work described on Page 8 and onwards has already been carried out and the gearbox and clutch housing removed from the engine. The four bolts (two on each side) which hold the front of the footboards to the tubular assembly will already have been removed.

Drain oil from the engine and water from the circulation system by removing the appropriate drain plugs from oil sump and cylinder heads respectively.

Uncouple the hoses from the radiator and cylinders and take off the water pipes. Disconnect the breather pipe from the crankcase breather to the air cleaner. Take out the two bolts from the engine fixing bracket. Remove the rubber buffers, rubber washers, fit these back over the bolts together with the plain washers and put back the nuts so as to keep them together for re-fitting. Disconnect the earth lead from the stud on the generator and detach the electric leads from the frame tube by taking off the rubber clips holding it.

The radiator and tubular assembly will now be easily removable.

### DISMANTLING CRANKCASE ASSEMBLY. REMOVAL OF INDUCTION PIPE AND CARBURETTER.

The induction pipe and carburetter may be taken off as described on Page 23 and if necessary the carburetter can then be taken off the pipe after loosening the clip bolt securing it.

NOTE that a gasket is used between the induction pipe stub and the carburetter. (See Fig. 25). This washer must be retained carefully for re-fitting.

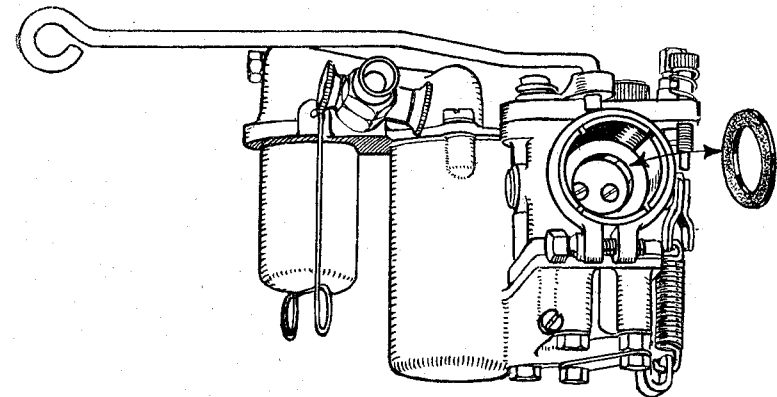

FIG. 25. The stub gasket of the carburetter which should be carefully preserved.



Remove the exhaust pipes and proceed as described on Page 24 to dismantle the cylinder heads and cylinders. Pull out all four tappets one at a time, marking each one as removed so that they may be replaced later in their respective guides.

#### REMOVING PISTONS.

The gudgeon pins are retained by spring circlips which fit into grooves in the bosses and prevent the pins working out sideways. Prise out one circlip by inserting the end of a small bradawl, or a cycle spoke ground to a point, below the circlip. Grooves are cut at the sides of the pistons to allow this to be done. Place a piece of rag over the piston boss in case the circlip "flies," and gets lost.

With a small brass or aluminium punch tap out the gudgeon pin from the opposite side; at the same time absorbing the force of the blows by holding the piston firmly to prevent bending or distorting the connecting rod. A low heat may be applied to the pistons if the pins are tight. Mark each piston on removal and see that they are replaced on the same side as they were originally fitted. Note also that the skirts are split and that the pistons are fitted with the split at the top on the right-hand side, and at the bottom on the left of the engine.

#### REMOVING THE OIL SUMP.

Remove the round domed oil filter cap from the sump by taking off eight 2BA nuts and locking washers. There is a separate pressure plate under the rim of the cap and this will come away when the nuts and washers are off (See Fig. 26). Carefully remove the gasket underneath the filter and preserve for re-fitting.

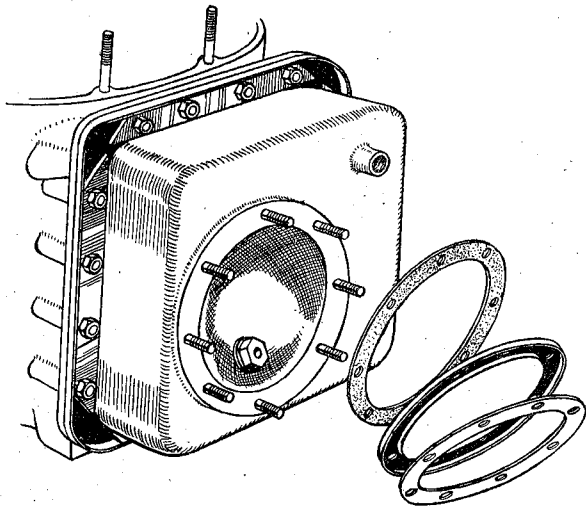

FIG. 26. Take out the hollow suction bolt before attempting to remove the wire gauze strainer from the sump.

**Warning.** The engine will get no oil if the filter cap is fitted upside down. The domed (convex) side must be downwards.

Unscrew and take out the hollow oil pump suction bolt which will be noticed holding the filter to the oil pump, and very carefully and evenly separate the filter from the oil sump, and pull it off the studs, trying not to damage the second gasket in the process, or distort the filter.

Wash the filter thoroughly in petrol and allow to drain and dry off. Do not in any circumstances try to clean it or dry it with rag, as fluff and lint will choke the mesh.

Sixteen 2BA nuts hold the sump to the crankcase. Take these off with the lock washers, and four pressure straps, one from the front and one from the rear, and one from each side. Carefully tap the sump to free it, and pull it off the studs; endeavouring to avoid damaging the oil sump gasket, which must be put aside for re-fitting if in good condition.

#### REMOVING THE REDUCTION GEAR PINION AND PLATE.

Stand the crankcase assembly up on the generator and insert a block of wood measuring  $2\frac{1}{2}$ -in.  $\times$   $\frac{3}{4}$ -in.  $\times$  1-in. between the crankshaft balance weight and the inner wall of the crankcase (Fig. 27). This holds the shaft from turning whilst undoing the pinion lock ring.

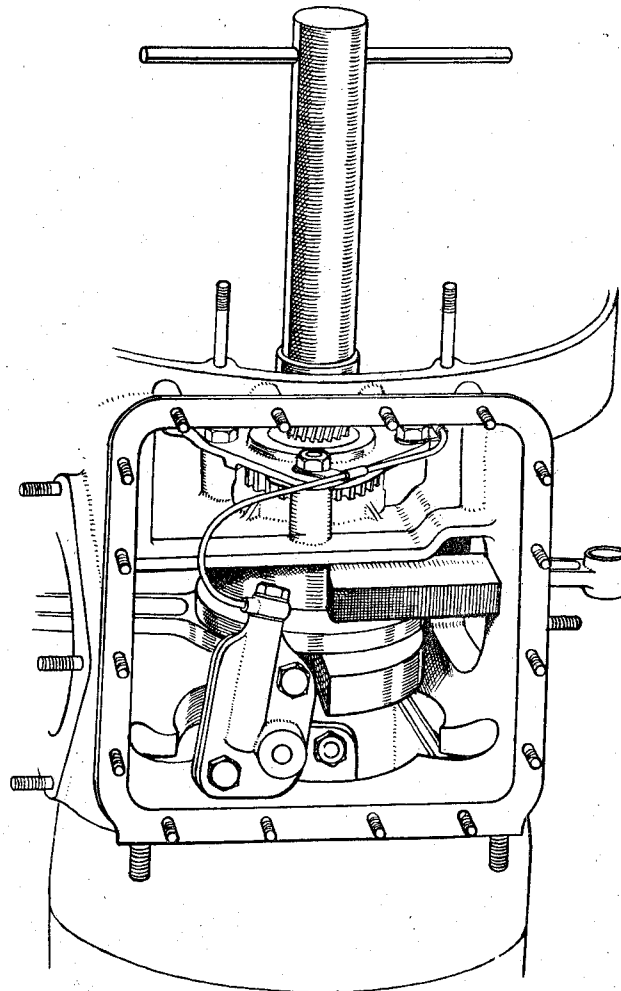

FIG. 27. A block of wood placed as shown will prevent rotation of the crankshaft while the lock ring is being removed with tool LET 780.

Bend back the tab of the lockwasher from the locking ring and remove the ring, using spanner LET780. Remove the tab washer, and withdraw the pinion from the driving shaft.

Unscrew the oil pipe banjo bolts securing the oil pipe to the pump and to the reduction gear plate. Do not lose washers which are used one at each side of each banjo union. In some cases the banjo bolt fitted into the reduction gear plate may not clear its threads before coming against the crankcase. In such circumstances leave it in place and take off the oil pipe with the reduction gear plate. Remove three  $\frac{1}{4}$ -in. nuts and the two  $\frac{1}{4}$ -in. nuts and bolts at the top. Take away the oil pipe—held by clips to the studs—and take off the reduction gear plate. The two bolts at the top are now fitted with special self-locking nuts and these must be kept with their respective bolts for re-fitting and not interchanged with other  $\frac{1}{4}$ -in. nuts from other parts of the engine. Note the dowel which may remain on the stud or come off with the plate, and keep it safely for re-fitting.

Draw the timing gear pinion from the driving shaft with the extractor LET802 (Fig. 28). This gear is a tight fit on the shaft, and is located in correct relation to the shaft by a key.

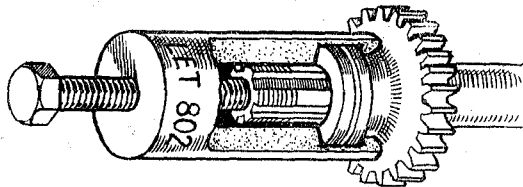

FIG. 28. Service Tool No. LET 802.  
Extracting Timing Pinion from Driving Shaft.

The generator is removed next as described on Page 63, followed by the removal of the flywheel (See Pages 64 & 65).

#### REMOVING THE CRANKSHAFT ASSEMBLY.

First remove the oil pump after taking off the oil pump nut and lock washer; pulling it down out of the flywheel housing.

Remove six nuts and washers holding the flywheel housing to the front of the crankcase; they are round the inside of the housing and are accessible from the front.

Place the crankcase inverted on the bench (sump aperture upwards). If not already removed, take out the wood block used to prevent the crankshaft turning, and revolve the crankshaft slowly until both connecting rods can be drawn up and held through the sump aperture.

Heat the crankcase carefully in the region of the driving shaft rear ballrace to free the race, tap the rear end of the shaft using a rawhide mallet and withdraw the crankshaft assembly and flywheel housing forward; guiding the connecting rods meanwhile through the extraction slots in the crankcase front face (see Fig. 29). Take away the gasket from the joint faces.

#### REMOVING THE CAMSHAFT.

Having removed the crankshaft and flywheel housing, place the crankcase on the bench resting on the rear face. Heat the crankcase around the rear camshaft ballrace and tap out the camshaft from the front, using a hammer and soft metal punch to avoid damaging the shaft.

As the camshaft clears the crankcase the front end ballrace will stay in the case and the rear one will be brought out with it.

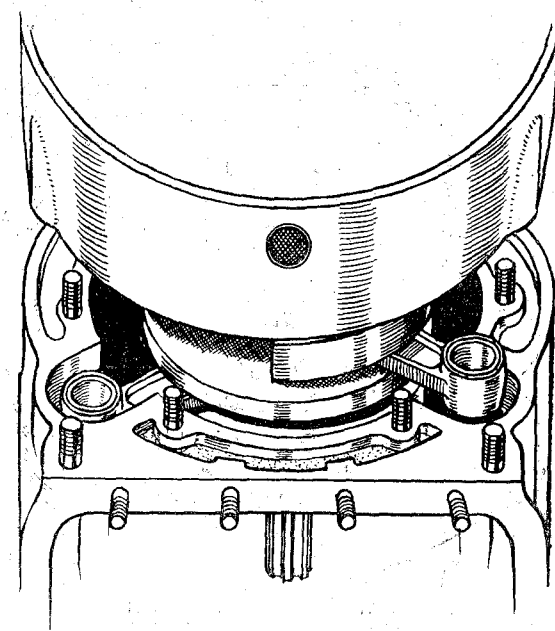

FIG. 29.  
Showing the slots through which the connecting rods must be guided.

If either the camshaft, the ballrace, or gear need replacing with new parts the shaft will press out of the gear if a small hand press is used, and if the camshaft key is taken out the ballrace may then be pressed off. The front ballrace may be tapped out of the crankcase after heating the ballrace housing. Note that the flat face of the camshaft gear faces the rear.

#### REMOVING THE CRANKSHAFT FROM THE FLYWHEEL HOUSING.

Unscrew and take out the three 2BA pins securing the oil seal housing to the flywheel housing (Fig. 30) and remove the oil seal housing and oil seal and the two washers. Screw the protector LET647/1 on to the end of the shaft.

Attach to the flywheel housing the extractor LET937, using three 2BA pins supplied with extractor and draw the flywheel housing off the shaft (Fig. 31). Do not attempt removal unless the correct pins are used. The oil seal housing pins are too short. Take care of the bearing location washer, which is fitted over the flywheel shaft against the balance weight.

The oil pump worm key may drop out of the shaft and should be noted and kept for re-fitting. With the current type of flywheel housing the large ballrace may remain in the housing or be left on the shaft. Take off the extractor LET937.

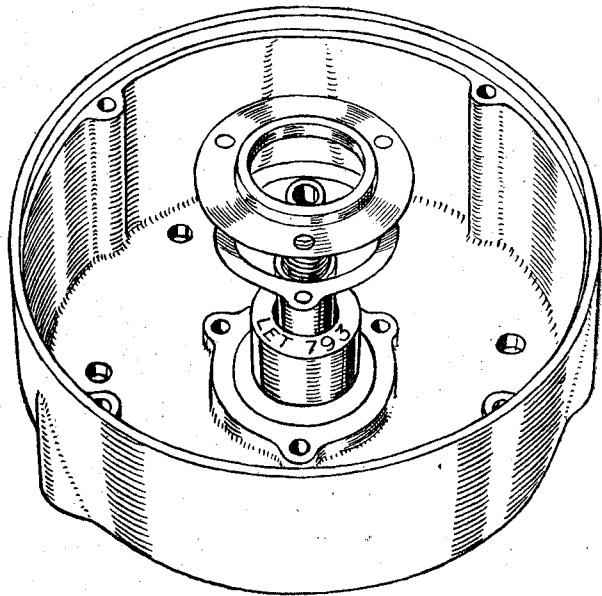

FIG. 30. The Flywheel Housing Oil Seal is centralised by the use of Tool LET.793.

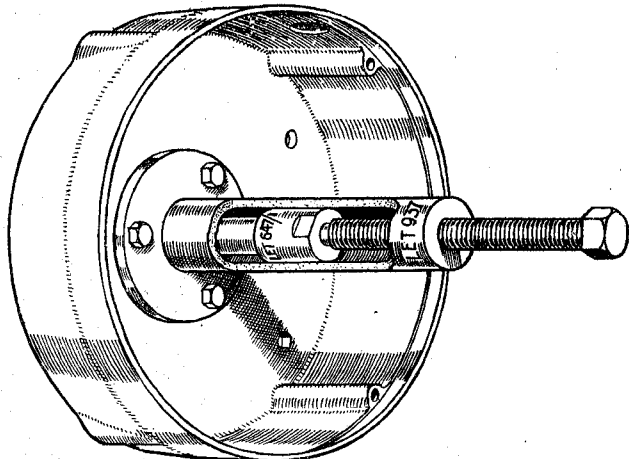

FIG. 31. Service Tool No. LET 937 and Protector LET 647/1. drawing flywheel housing and bearings from shaft.

#### REMOVING THE BEARINGS FROM THE FLYWHEEL HOUSING.

Unscrew the four 2BA studs from the front of the housing, heat up the housing in boiling water. When hot enough, remove from the water and bring the front face of the housing down smartly on to the bench or a block of hard wood and jarr out the front ballrace. The oil pump worm will then fall out.

The current type flywheel housing has a circlip behind the front ballrace, but earlier types have a circlip behind the large rear ballrace. With this pattern the large ballrace is always drawn off with the housing, and the circlip must be taken out before attempting to get the bearing out. Whichever pattern is being dealt with, however, the housing must be heated up again and the bearing tapped out of place, after removing the large circlip.

#### REMOVING CRANKSHAFT BALLRACE.

The large crankshaft front end ballrace may have come away with the flywheel housing but the rear one will be left on the mainshaft. To remove the ballraces the extractor tool LET928 will be needed.

To remove the rear ballrace unscrew the centre screw of the extractor and fit the extractor claws over the ballrace between the outer ring and the crankshaft web (Fig. 32). Tighten down the centre screw and draw off the ballrace.

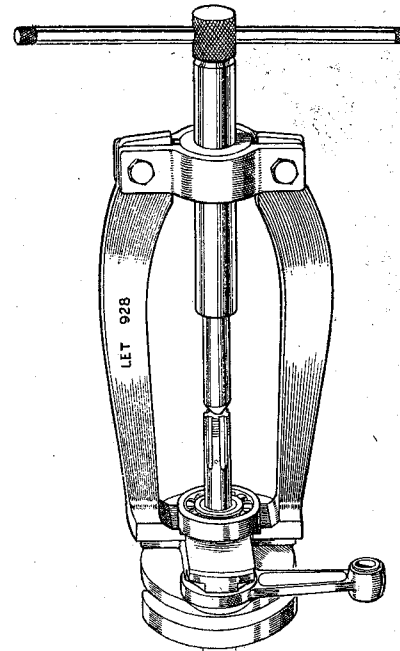

FIG. 32.

Service Tool No. LET 928. Withdrawing crankshaft ballrace.

Should the front ballrace have remained on the flywheel shaft it may be drawn off in a similar manner, but the protector LET647/1 must be fitted to the end of the flywheel shaft before using the extractor. **NOTE SPECIALLY.** Between each ballrace and the balance weight a bearing location washer is fitted.

#### RE-FITTING THE CRANKSHAFT REAR END BALLRACE TO THE DRIVING SHAFT.

Place the ballrace location washer over the driving shaft with the recessed side against the balance weight and mount the crankshaft with

the ballrace uppermost on the fixture LET807 (Fig. 33) as for pressing out the crankpin, but bring the driving shaft immediately under the ram of the press. Using a suitable bush or sleeve over the flywheel shaft to contact the centre ring of the ballrace, press the ballrace up to the location washer.

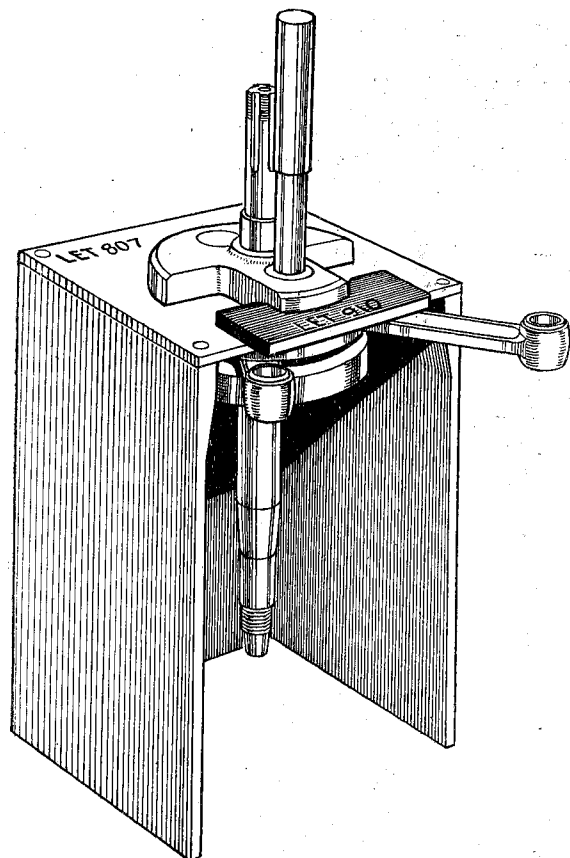

FIG. 33.

Crankshaft Assembly Tool No. LET 807, and Assembly Tool Plate No. LET 910.  
Crankshaft shown in position for pressing crankdisc out of balance weight.

The front end ballrace is fitted to the flywheel housing and is replaced when the flywheel housing is fitted.

#### DISMANTLING THE CRANKSHAFT ASSEMBLY.

The driving shaft and flywheel shaft balance weights are pressed on to the tapered ends of the crankpins formed integral with the centre crank disc.

Before separating the balance weights from the crank disc mark the crankpins and balance weights to ensure that the disc is fitted correctly on re-assembly. The correct way to fit the disc is described on Page 38, should there be any doubt.

To separate; place the crankshaft assembly on the fixture LET807 as shown (Fig. 33) and with the packing strip LET910 in position, press out the crankpin from the balance weight. Take off the big end washer and the connecting rod, and rollers; noting the position of the small end oil hole in the rod for correct reassembly. The connecting rods are interchangeable but should be put back in their original positions, and should accordingly be marked. Indelible pencil is a suitable means of marking.

Invert the crankshaft and press out the other crankpin in a similar manner. Take off the outer crank disc washers and if in need of replacement draw off the big end sleeves and the inner washers.

#### REPLACING SMALL END BUSHES.

It is unlikely that the small end bushes will need to be replaced before the big end bearings need attention but should a new bush or bushes have to be fitted without the crankshaft having been taken out and the connecting rods removed the work of replacing a worn bush can be done with the crankshaft and connecting rods in place and only the appropriate cylinder and piston removed.

If the crankshaft has been taken out of the engine and dismantled the worn bush may be pressed out of the connecting rod, using a mandril and bush of suitable sizes and employing a hand press. The new bush is also pressed in in the same way.

The bush must be fitted centrally, and when finally pressed into place the location of one side face must be checked in relation to the ground side face of the big end on the same side.

The distance, which is most important, is .2365 inch. The dimension is shown (Fig. 34) below.

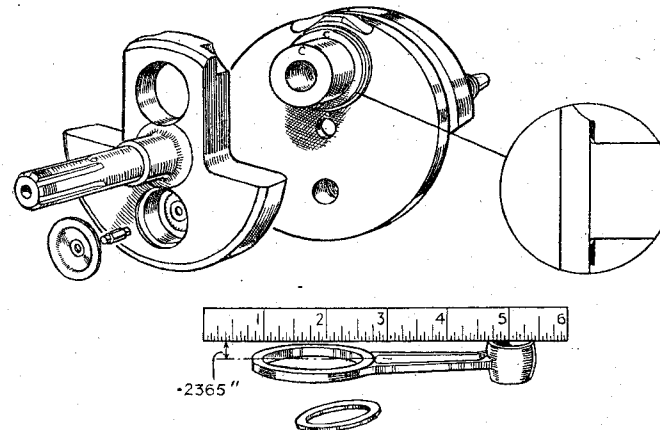

FIG. 34.

The Crankshaft Assembly showing centrifuge sludge trap opened for cleaning. Inset shows hardened ring in place.

The oil receiver cup and the oil feed hole are shown below the crankpin. The straight edge indicates the correct setting for the small end bushes.

Bushes may be withdrawn with the connecting rods in place in the engine by means of a draw bolt and bush of suitable sizes and new bushes fitted in the same way. Care is necessary to avoid distorting the connecting rods, and as it is not possible to check the face of the bush in relation to the big end the bush must be set as accurately as possible so that an equal amount stands proud of the small end eye on each side.

If not correctly fitted one or other of the end faces of the bush will thrust against the inside of the piston boss and force the piston hard against the cylinder wall on that side, so that great care is needed when rebushing in situ to prevent this.

Finally ream the bush to an internal diameter of .500 inch + .00025 - .00025.

### RE-FITTING BIG ENDS OR FITTING NEW SLEEVES AND RODS.

To reassemble first fit the inner washer, making sure that the recessed face fits against the face of the crank disc and over the radius at the corner of the pin.

Crank discs and big end sleeves are graded in sizes and are marked A.A., A, B and C. Grade AA is the smallest and the others progressively larger in the order given. When fitting new sleeves note the grading letter on the crankpins and select and fit sleeves bearing the same markings. They are marked on the side face.

Press a new sleeve over the crankpin, following it with the outer washer.

Neither the crank disc nor the balance weight assemblies can be renewed as separate items. In any instance when a new balance weight, or crank disc becomes necessary, the crankshaft assembly must be fitted. Connecting rods are not included in this assembly—they can be supplied separately and are produced in four sizes.

The grade number indicating size is etched on the foot of the rod. The grades are 1, 2, 3 and 4, of which No. 1 is the smallest. The sizes increase by .00015-in. 4 is the largest size.

Big end rollers are available in three sizes, part number LE13 being standard. The sizes are:—

L.E.13	Roller (standard diameter)	.125-in.
LE13/6	„ first oversize	.125-in. + .0004-in.
LE13/5	„ second „	.125-in. + .0006-in.

There are 68 rollers per machine, 34 in each big end.

When the rollers are fitted there should be no slack in the big end, but it must be perfectly free.

With a selection of graded connecting rods, and the three sizes of rollers the correct fit is easily obtainable.

**Note when putting connecting rods on the crank disc that oil holes to the small end bushes are facing the crank disc.**

Refit the outer washer and place the balance weights in position for pressing on.

### REASSEMBLING THE CRANKSHAFT ASSEMBLY AND LINING UP.

Be most careful to check that the driving shaft and balance weight (the rear ones) carrying the big end oil jet is fitted facing the oil receiver cup which is turned in the crank disc centre. Refer to Fig. 34 before fitting, and also make certain that the driving shaft oil passage has been cleaned out properly and the jet replaced, see Page 49. Also clean the sludge trap.

This will entail punching out the rivet to remove the washers so as to clear all accumulations of sediment from the circular space in the driving shaft balance weight. New washers and a new rivet will be needed on reassembly and should be obtained beforehand. (Fit. '34).

Having refitted the rollers, connecting rod and washer on one crankpin, replace the appropriate balance weight over the crankpin, pushing it lightly into place.

Refit the balance weight to the other crankpin and push lightly into place.

Now line up the assembly, getting the outside diameters of the two balance weights and the crank disc exactly in line by checking along all three with a straight edge.

After this, set up the assembly in centres, or on V blocks mounted on a surface plate, and check for accuracy with a Dial gauge, taking readings on the driving shaft, the flywheel shaft, and the outer diameters of the two balance weights and the crank disc. The two shafts must be made to run true with the outside diameter of the crank disc. It is possible in certain circumstances for the two shafts to be made to run within .0005-in. of perfect accuracy, but when a reading is taken off the crank disc this may be found to be over .018-in. out of truth. If this happens, suspect that one or both balance weights have been pressed on slightly askew. A sharp tap on the balance weight concerned will correct the error. Tap with a lead or copper hammer, as otherwise the balance weight will be marked.

**The flywheel shaft, driving shaft, and crank disc must all be made to run within .0005-in. of accuracy.**

When satisfied that they are true, press home the balance weights fully on to the crankpins. This can be done by supporting the crank disc on the fixture LET807.

### REASSEMBLING THE CRANKSHAFT ASSEMBLY INTO THE FLYWHEEL HOUSING.

Heat the flywheel housing in boiling water, and when it has reached the correct temperature drop the larger ballrace into place and, in the case of an earlier type housing, refit the large circlip.

Refit the bearing location washer over the shaft with its recessed face against the balance weight. Place the flywheel housing into position over the shaft and screw the body of the crankshaft assembly tool LET924 (Fig. 35) on to the end of the shaft. Put on to this tool the long bush and follow it with the nut. Continue tightening the nut until the ballrace is hard up against the location washer. When fully home remove the tool from the shaft.

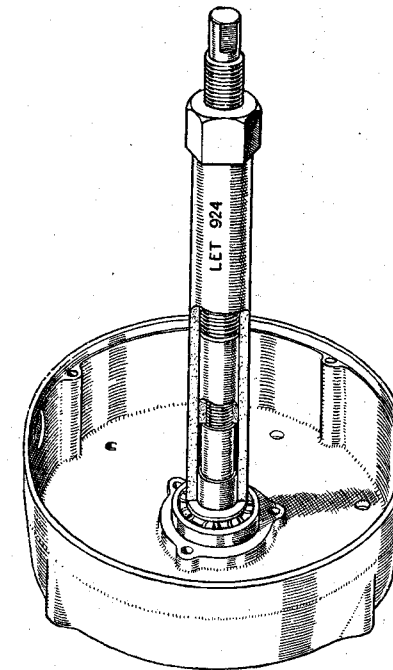

FIG. 35.

Service Tool No. 924.  
Drawing Flywheel Housing  
and Bearings onto shaft.

Put the oil pump drive worm in position on the flywheel shaft, noting before doing so that the length of the boss on one side of the worm is shorter than the other. The worm must be fitted so that the shorter boss is against the larger of the ballraces in the flywheel housing. Fit the pump drive worm key.

As mentioned previously a circlip is now fitted to a groove in the forward bearing housing to locate the smaller ballrace. If there was no circlip, or provision for one behind the rear bearing in the housing, see that the circlip is in place at the forward end.

Heat the flywheel housing in the vicinity of the bearing boss and drop the ballrace over the shaft, and again using service tool LET924, press the ballrace on to the shaft and into the housing until it is up against the oil pump worm. Refit the two flywheel shaft dished washers.

Coat the oil seal housing joint face and the matching face on the housing with Gasket Goo, refit the gasket, or a new one, in place and fit the oil seal housing and oil seal loosely in position with the three bolts in their places. Centralize the oil seal with the centralizing tool LET793 (Fig. 30) and tighten the fixing bolts. (See also Page 61).

#### FITTING CAMSHAFT FRONT END BALLRACE.

Heat the crankcase around the ballrace housing, and using the bar as shown in Fig. 36, tap the ballrace into the housing making sure that it is fully home.

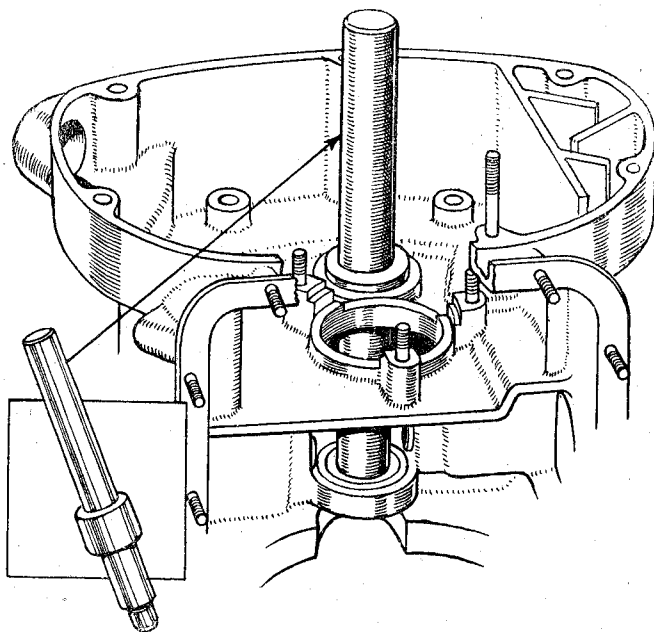

FIG. 36.

Tap the forward camshaft bearing into position by means of the bar shown in this illustration.

#### REPLACING CAMSHAFT REAR END BALLRACE.

Using a hand press and a suitable bush press the camshaft into the ballrace. Refit the key to the shaft and start the camshaft gear on the shaft, locating the keyway in the gear with the key and seeing that the flat face of the gear with the etched timing mark (Fig. 37) faces away from the ballrace. Using a hand press, press the gear on to the shaft until it is firmly up against the ballrace.

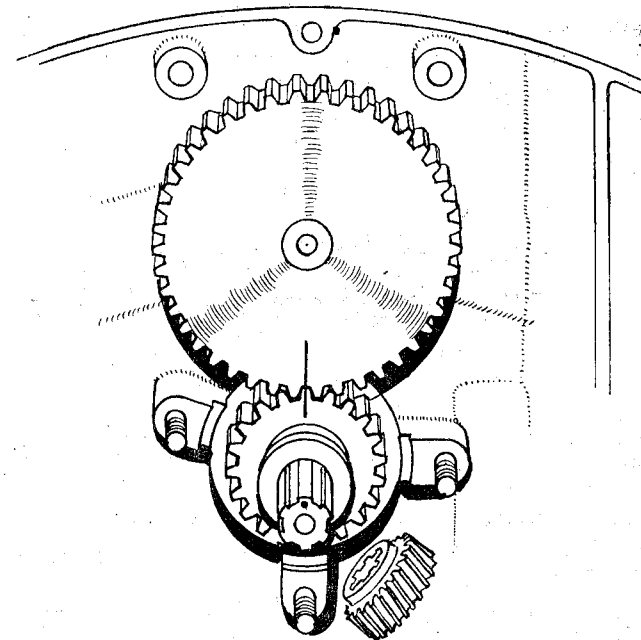

FIG. 37.

Mesh the timing gears by the etched marks.  
Fit the reduction gear pinion with the reduced face towards the driving shaft collar.

#### REFITTING THE CAMSHAFT TO THE CRANKCASE.

Heat the crankcase around the housing for the camshaft rear end ballrace, and push the camshaft through from the rear, entering the front end in the front ballrace and the rear ballrace in its housing. Tap the shaft fully home.

The tappets may be left for refitting just before the cylinders are put back.

#### REFITTING THE CRANKSHAFT ASSEMBLY INTO THE CRANKCASE.

Place the flywheel housing gasket carefully over the face of the flywheel housing, sticking it in place with a light coating of jointing compound or grease and registering the stud holes in it with the stud holes in the face and making sure that the irregular outer edge matches the edge of the housing.

Warm the crankcase around the driving shaft ballrace housing at the rear end, and with the crankcase resting on the bench front face upwards, feed the crankshaft assembly into the crankcase, passing the connecting rods through the slots provided in the case. Turn the housing until the stud holes register correctly with the studs.

Enter the driving shaft bearing into the rear housing in the crankcase and push the flywheel housing home over the studs and up to the face.

Fit the washers and nuts and tighten up each a little at a time and evenly until fully tightened.

#### REFITTING THE TIMING GEAR PINION.

Fit the timing gear pinion on to the driving shaft, seeing that the key enters the keyway in the gear and that the etched line on the face of the gear is in line with the corresponding mark on the camshaft gear wheel. Push home the pinion with the timing pinion assembly tool LET915 (Fig. 38) and check that the gears are meshed with the timing marks in register (Fig. 37).

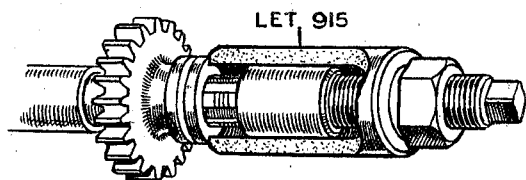

FIG. 38. Service Tool No. LET 915 pressing timing pinion on driving shaft.

Check carefully that the oil hole through the pinion bearing collar through which the oil passes into the hollow driving shaft is quite clear and unrestricted.

#### FITTING THE REDUCTION GEAR PLATE.

Fit the dowel into the counterbored hole in the crankcase (top left of the timing gear) to locate the reduction gear plate. As the oil pipe banjo bolt may not go into place after the plate is fitted, attach the oil pipe to the plate with the banjo bolt fitted finger tight before putting the plate into place. Note that one copper washer must be fitted at each side of the banjo.

Oil the bearing collar on the timing pinion and put on the plate over the studs and bearing collar. Push through from the inside of the crankcase at the top the two  $\frac{1}{4}$ -in. bolts and fit the nuts. Latterly, self-locking nuts have been used on these bolts and must be replaced on them. Also fit all the other washers and nuts and tighten securely.

Fit the reduction gear pinion with the reduced face towards the timing pinion (Fig. 37). Place the tab washer and the lock ring on the shaft. As shown on Page 31, fix a block of wood against the driving shaft balance weight, and tighten the lock ring, using spanner LET780 (Fig. 16), giving the spanner two or three blows with a small hammer to secure the lock ring. Do not use excessive force. Bend a tongue of the lock washer into a serration in the lock ring.

#### REPLACING PISTONS AND RINGS.

In the ordinary way new piston rings and oil control rings should not be required until the time comes to rebores the cylinders and fit oversize pistons and rings. If the rings are bearing evenly on the cylinder walls refit them. In many ways it is unsatisfactory to fit new rings to partly worn cylinders as they take a long time to bed into and settle down properly to bores which may no longer be truly circular or parallel. Obviously a broken ring must be replaced.

When fitted to new or rebored cylinders new rings must have a gap when in place of .007 to .012-in. New rings supplied by us are correctly gapped and should not need filing. When fitted to part worn bores the gaps will almost certainly be greater.

Never attempt to fit rings which are oversize in diameter to cylinders—even part worn ones—whose original bore was smaller than the diameter to which the rings are ground. The original bore can usually be found by measuring the bore diameter just inside the mouth where the walls are not traversed by the rings.

**The pistons must always be put back into their respective cylinders. Note also that the slot in the piston skirt must be uppermost on the right-hand side and underneath on the left.**

Oil the gudgeon pin and push it into the piston boss until the end just protrudes beyond the boss inside the piston. Fit the piston over the small end of the rod entering the gudgeon pin in the small end bush.

Tap the pin through the piston and bush, supporting the piston from the opposite side to avoid bending or distorting the connecting rod. When it has come up against the circlip which was left in place when dismantling, refit the circlip on the other side, making absolutely sure that it is properly seated in the circlip groove.

Set the piston rings so that the gaps are equally spaced round the piston and refit the cylinders as described on Page 27.

Re-adjust the tappets—See Page 23.

#### REFITTING THE FLYWHEEL. (With B.T.H. Generator only —if Miller generator see Page 66).

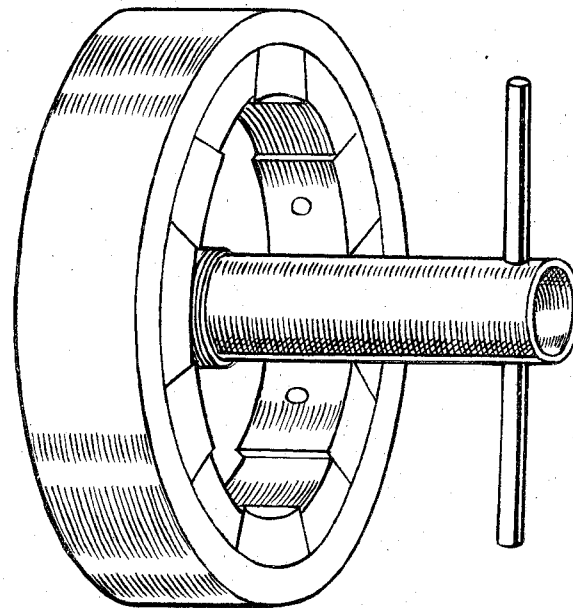

FIG. 39.

Tightening Miller Flywheel Nut with  $\frac{1}{2}$ -in. Whitworth tubular spanner. For the B.T.H. generator the outside diameter of the spanner round the hexagon nut must not exceed  $1 \frac{3}{32}$ -in.

See that the taper in the flywheel and the taper on the shaft are clean and fit the flywheel on to the taper. Take the bush LET793 (Fig. 30) or stout tube 1-in. long, and just over  $\frac{1}{8}$ -in. inside diameter and push this over the shaft. Screw on the flywheel shaft nut, chock the crankshaft as described before with a block of wood, and tighten the nut. A  $\frac{1}{2}$ -in. tubular spanner (Fig. 39) is needed and the tommy bar should be given a few sharp taps with a light hammer to ensure that the nut is fully tightened. Remove the wood block.

Remove the nut and bush, leaving the flywheel tight on the taper. Fit the four flywheel housing studs to the housing; fit the flywheel shaft generator key.

Place the crankcase on the bench standing on the clutch housing face, and turn the crankshaft until the key is at the top (i.e., 12 o'clock). Refit the generator and retime the ignition (See Page 50).

Screw in the sparking plugs to the cylinder heads and refit the heads as described on Page 28. Refit the high tension leads.

### REFITTING THE OIL PUMP AND OIL PIPE.

Stand the crankcase assembly upside down on the bench, leaving the sump aperture uppermost. Place the pump in position in the opening in the flywheel housing engaging the pump spindle gear with the driving worm. Fit the washer and nut and tighten.

Fit the oil pipe to the pump, with the banjo hollow bolt, making sure that one copper washer is used at each side of the banjo. The other banjo union and the oil pipe clips should have been fitted when refitting the reduction gear plate (See Page 45). Tighten the banjo bolt carefully.

The open end of the oil pipe has to be set so that it clears the large reduction gear fitted to the clutch housing assembly when this is put into place, also see that it will feed oil directly into the oil feed hole for the clutch housing bearing.

### REFITTING THE OIL SUMP.

Fit the sump gasket, using a new one if the original is damaged at all, and place the sump into position over the studs.

Put on the four pressure straps, followed by the sixteen washers and 2BA nuts. Tighten the nuts evenly and carefully.

Fit the upper filter gasket, or a new one if needed, followed by the filter, which must be positioned so that the hole in it for the oil pump suction bolt will allow the bolt to go through it into the pump (Fig. 26).

**SPECIAL NOTE.** As the whole of the oil supply for the engine has to pass through the suction bolt see that it is quite clear before fitting it.

Carefully tighten the bolt, and fit the second gasket, the filter cap, the pressure plate, washers and nuts. Tighten evenly.

**Warning.** The filter cover must be put back the right side up (Fig. 26).

### REFITTING THE CLUTCH HOUSING TO THE CRANKCASE ASSEMBLY.

When rebuilding the engine and gearbox unit, the clutch housing assembly must be fitted to the crankcase first, and the gearbox assembly attached to it afterwards.

See that the top end of the oil pipe is turned outwards well proud of the crankcase joint face (Fig. 40). See that the two dowels are in place and fit a new joint washer sticking this to the face with grease. Jointing compound is unnecessary on this joint.

Offer up the clutch housing and tip it slightly so that the upper edge of the large reduction gear passes under the bent down end of the oil pipe. Level up the housing and engage the two bottom holes over the two bottom studs which protrude from the crankcase. Press the housing forward gently so that it bears against the oil pipe, with the pipe in the small recess just above the clutch housing bearing. Fit the washers and nuts to the studs and tighten down enough to hold the housing against the crankcase but do not tighten them fully at this stage.

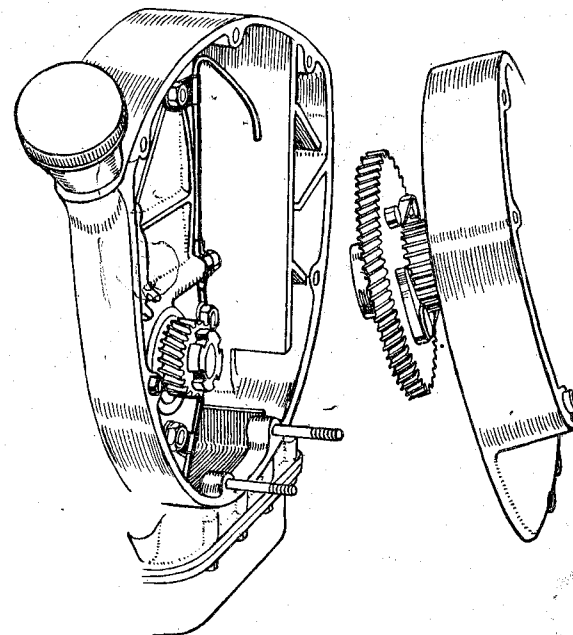

FIG. 40.

Small Oil Pipe bent well outwards, Clutch Housing tipped so that reduction gear misses end of pipe. Push forward and bring clutch housing upright to engage holes over two lower studs.

### FITTING THE GEARBOX.

Before mounting the gearbox on the clutch housing the starter shaft has to be held up so as to clear the operating end of the starter lever shaft when the gearbox is pushed forward into place.

Leave the starter spring free and pull up the operating end of the starter shaft as far as it will go, turning the crankshaft by rotating the clutch, and tie it up into place with a stout cord. See that the loop of the spring is fitted over the lever as illustrated (Fig. 41) and then hook the other end of the spring up and catch it over the stud as shown.

See that the two dowels are in place, and line up the clutch Ferodo plates so that they enter the clutch bell, and then push the gearbox over the studs until a gap of about  $\frac{1}{8}$ -in. is left between the faces of the gearbox and the clutch housing.

Through the gap left, press the leg of the spring upwards on to the top of the boss of the stud on which it was resting, using the end of a screwdriver for the purpose. When this has been done remove the cord and push the gearbox fully home. Fit the five washers and nuts and tighten up fully, and also tighten the two bottom nuts holding the clutch housing to the crankcase.

### REFITTING THE FRAME CROSS MEMBER TO THE ENGINE AND GEARBOX UNIT.

When dismantling, the rear cross member was removed, together with the stand, brake pedal and footboards attached to it, and should be refitted with these components.



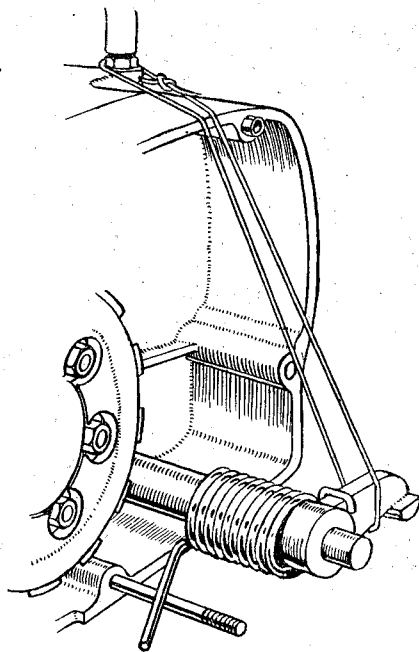

FIG. 41.

Fit the Starter Spring as indicated, and tie the arm with string to the breather pipe union to hold it against the spring.

Replace the seven rubber buffers on the studs at the back of the gearbox. Fit the cross member over the buffers and put on the rubber rings, followed by the plain washers and  $\frac{1}{16}$ -in. nuts, and tighten the nuts fully to the shoulders on the studs.

#### REFITTING FRAME TUBE ASSEMBLY AND RADIATOR.

Bring the frame tube assembly up into position in front of the engine unit and push up, through the appropriate lugs, the two engine fixing bolts, placing over them and above the lugs the two rubber buffers with the flanges downwards and against the lugs. Push the tubular assembly up towards the engine fixing bracket, entering the buffers in the boltholes in the brackets. Put the rubber rings over the bolts, fit the plain washers and nuts, and tighten down to the shoulders of the nuts.

Refit the pipes from the bottom of the radiator to the cylinders, the longer of these two pipes fits on the right-hand side (facing forward). Also fit the water outlet hoses and tighten all clips securely.

Replace the air intake sleeve and the breather pipe.

Instructions for refitting the rear fork assembly and bevel drive appear on Page 60.

#### REFITTING THE FRAME TO THE ENGINE UNIT.

Place the unit across a trestle or box as for dismantling. Verify that the clutch control cable is connected to the lever on the gearbox and passed through the stop lug on the gearbox top cover.

Bring the forward end of the clutch cable between the radiator top and underneath the top cross tube of the front frame tubular structure on the left of the machine. The placing of the cable in this way is very important. Connect the speedometer flexible drive to the gearbox.

Lift the frame assembly over the engine unit and pass the speedometer flexible drive over the bottom left-hand fixing bracket of the fuel tank. If this is not done the drive will become too sharply bent when the frame is in position.

Lower the forward part of the frame until the steering head lug has located between the two lugs at the top of the tubular structure.

Now lower the rear of the frame, making sure that the lighting cables are placed correctly, until it rests on the top of the rear fork hinge pins. The sides of the frame will have to be sprung out slightly before it will slide down over the flanges of the hinge pins.

Line up the holes in the frame with those in the flanges and fit the hinge pin bolts and washers. Two are used at each side. Replace the C shaped nut plates (Fig. 3) and screw in the bolts but do not tighten them for the present.

Put back the four bolts, and washers—two at each side—holding the tubular construction to the steering head. Tighten these bolts and also the four hinge pin bolts at the rear.

Support the front wheel, the fork and front mudguard assembly and push the steering column up into the steering head.

Note that if the machine has cup and cone ball bearings in the steering head the balls must first be stuck into the lower ball cup with stiff grease to hold them in place whilst the column is replaced. In the ball bearing type 38  $\frac{1}{4}$ -in. dia. balls are used per machine—19 in each race.

Make sure that the steering column felt washer is in place on the steering column assembly.

Refit the top bearing, the dust cover, and the steering column lock nut. Screw this down sufficiently to hold the column just stiffly in the bearings, after which the support for the wheel may be dispensed with.

#### ADJUSTING THE STEERING HEAD BEARINGS AND FINAL ASSEMBLY.

This is carried out in the same way regardless of whether ball bearings or taper roller bearings are fitted. The bearings are in fact interchangeable.

Check the movement of the column in the steering head and if free tighten the nut down until the column is just stiff to move from side to side. Then gradually slacken back the nut until the column becomes quite free whilst at the same time there is no trace of slackness or play in the bearings.

Fit the fork top cross member, pulling the wheel forward if necessary to get the cross member over the boss of the column lock nut and the two fork struts.

Finally refit and tighten the head lock nut assembly. Fit the handlebar with headlamp and switch panel. Now refit the following:—Dipper switch to handlebar, wires to electric horn, clutch cable to carburetter, petrol pipe to carburetter, both legshields, top cover to right-hand legshield and left-hand cover with speedometer to the other legshield.

Re-connect all electric cables, checking the colour markings to ensure correct working, and connect up the speedometer flexible drive to the instrument. See Pages 77 and 83.

Push the gear lever down through the opening in the frame and screw it on to the gear lever end. If, when tightened fully, the lever is in such a position that selection of all three gears is difficult or perhaps impossible, note which way the lever needs setting, unscrew it again, remove it and bend it carefully to give the correct position. Refit knob.

Raise the rear fork assembly and pass the bolts at the tops of the rear spring strut assemblies through the slots in the mudguard. Fit the washers and screw down the long bolts after setting the struts in similar positions along the slots (Fig. 42).

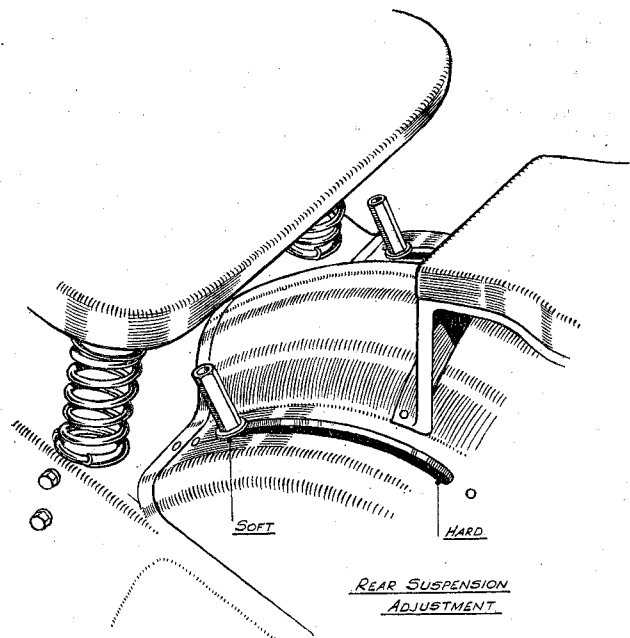

FIG. 42.

Replace the rear wheel, its distance piece and spindle as detailed on Page 72. Re-adjust both brakes and connect the cables to the battery. Note the positive (+) terminal is connected to "earth."

#### DESCRIPTION OF ENGINE LUBRICATION SYSTEM.

Beginning with engine number 200-11324 a modified lubrication system has been used (Fig. 43).

The oil pump jet previously used has been deleted and replaced by a plug to blank off the oil jet hole in the pump body. All the oil from the pump is now delivered along the oil pipe to the reduction gear plate and from thence to the driving shaft plain bearing in the plate. From this bearing the oil feeds into a groove in the timing pinion collar which runs in the bearing and from this groove enters the hollow driving shaft through a radial drilling in the collar and shaft.

A jet pressed into the forward end of the driving shaft directs a stream of oil into a receiver cup formed in the centre of the crank disc immediately opposite the jet.

From this cup oil holes drilled radially in the crank disc take the oil directly to the big ends. One drilling of  $\frac{1}{16}$ -in. diameter feeds the "aft" big end, and two  $\frac{1}{16}$ -in. holes feed the forward one.

Additionally a drilling .030 inch diameter breaking into the oil passage in the reduction gear plate directs a jet of oil on to the timing gears, and the oil pipe is continued up past the banjo union on the reduction gear plate and feeds oil on to the clutch housing bearing.

The open end of the pipe is reduced to  $\frac{1}{8}$ -in. diameter in order to restrict the flow in this direction and balance the supply correctly to the parts requiring it.

An additional refinement introduced in the design is a sludge trap in the driving shaft balance weight. Any impurities of a solid nature which may have found their way into the oil are carried by centrifugal force along a radial drilling in the balance weight and lodge in the cavity in the balance weight.

Should a crankshaft be dismantled it is advisable to remove the oil jet in order thoroughly to clean out the oil ways. The jet is removable by screwing into it a  $\frac{1}{2}$ -in. diameter screw after tapping it out with the required size thread and the jet is recessed for this purpose. A new jet will, of course, be needed.

At the same time the "sludge trap" in the rear balance weight should be opened and any accumulation of foreign matter cleaned out. Also clean out the radial hole from the drilling in the mainshaft which leads to the "sludge trap." The rivet must be punched out or the head ground off to remove the washers and new washers will be essential when reassembling.

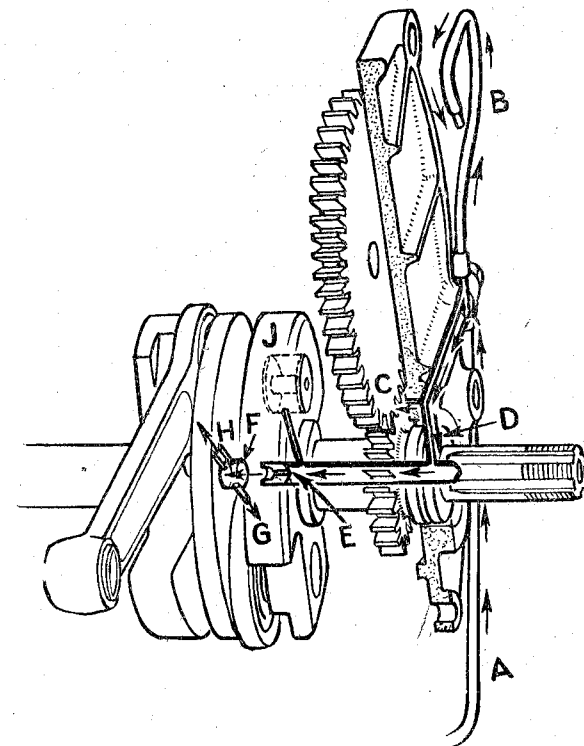

FIG. 43 Diagram of Engine Lubrication System.

- |  |                                 |
|--|---------------------------------|
| A. From oil pump.                                | E. Through jet to - -           |
| B. To clutch housing bearing.                    | F. Cup in crank disc.           |
| C. Through reduction gear plate to timing gears. | G. Single hole to rear big end. |
| D. Through timing pinion collar to main shaft.   | H. Two holes to front big end.  |
|  | J. Indicates the sludge trap.   |

The new washers are easily fitted, one being fitted to the rivet and the end of the rivet hammered over. Note that the recessed sides of the washers are placed outwards. Pass the rivet through the balance weight and the washer in place. Fit the second washer into the recess in the balance weight and over the rivet, and hammer over the rivet to secure.

When reassembling the centre disc to a crankshaft it is essential to fit it so that the oil receiver cup faces the rear driving shaft balance weight. This is most important.

The illustration, Fig. 34 will assist in the understanding of the above description.

### RETIMING THE IGNITION.

The ignition timing is set with the automatic timing unit in the fully retarded position.

The position is verified when a B.T.H. generator is fitted by noting whether the punch dot on the small pinion is directly opposite to a depression in the side face of the cam. In this position the unit is fully retarded (Fig. 44).

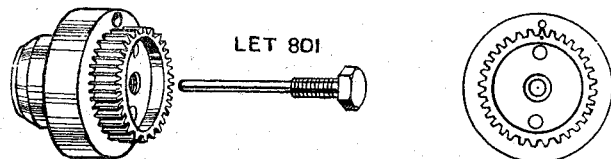

FIG. 44.

B.T.H. Timing Unit (Retarded). Showing Extractor Tool LET801.

The Miller timing unit is in the retarded position when the governor weights are fully closed behind the front slotted plate of the unit and the governor weight springs fully closed (Fig. 45).

The contact breaker gap must be accurately adjusted before retiming; the clearances being .012-in. for the BTH unit and .014-in. to .018-in. for the Miller. As the setting is very critical on the latter, it is advisable to fit the timing unit firmly on the taper before retiming and set the contact breaker point gap. Next free the timing unit from the taper with the extractor tool LET948 and set the timing.

Drain off the water and remove the left-hand (nearside) cylinder head. Rotate the crankshaft in the normal direction of rotation until the two valves in the left-hand cylinder are shut, and the piston exactly at top dead centre. This is top of compression stroke and the point at which the spark must occur.

Set the ignition cam so that the contact points just separate at this point and tighten the cam on to the flywheel shaft.

The exact instant that the contact points separate can be checked if a Miller generator is fitted by switching on the ignition, with the battery in circuit, and watching the warning light. The light will be on when the points are touching and will go out immediately they separate.

With a BTH generator see that the distributor gear wheel is correctly meshed with the small pinion. With the left-hand piston at top centre of compression stroke as set, the mark on the distributor gear must register with the mark or the dots marked on the crankshaft pinion of the timing unit.

### THE REAR BEVEL DRIVE.

### REMOVING THE BEVEL CASING COVER, CROWN WHEEL SHAFT ASSEMBLY AND FIXED SPINDLE.

Drain the oil from the casing. The drain plug is in the flat base of the casing. Remove the rear brake shoes.

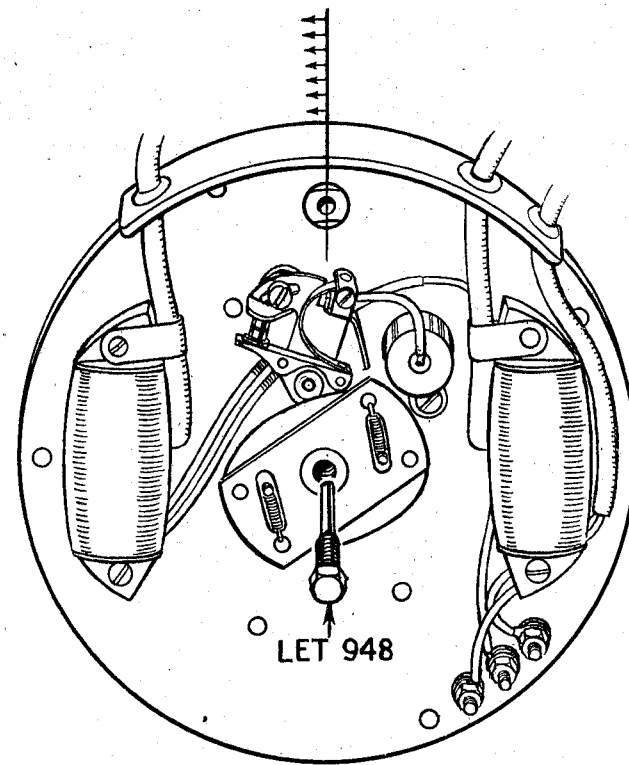

FIG. 45. Resetting Miller Flywheel. Dowel hole in flywheel is shown set central in relation to hole in Stator Plate at top dead centre. The Timing Unit is shown in full retard position. Note also Extractor Bolt Service Tool No. LET 948 for withdrawing timing unit.

Take off eight  $\frac{1}{4}$ -in. diameter nuts and lock washers from the cover studs. From the opposite side—the brake side—tap gently on the end of the fixed spindle with a rawhide hammer; the cover with the crown wheel shaft assembly and fixed spindle will withdraw from the bevel casing. If possible prevent the joint washer from being damaged.

Two dowels fit over the top and bottom studs. One or both of these may stay attached to the casing, or if free fitting, may come off with the cover. See that they are kept carefully for reassembling later.

Remove the rollers from the crown wheel shaft. There are 23 to the set.

### REMOVING THE FIXED SPINDLE FROM THE CROWN WHEEL SHAFT.

Fit the clamping tool LET790 over the plain diameter of the fixed spindle and hold the tool firmly in a vice. Do not overtighten, as this will distort the spindle (Fig. 47).

With the bevel cover uppermost remove the locking by unscrewing with tool LET780. (The current type housing is shown in Fig. 47).

Remove the assembly from the tool in the vice and tap out the fixed spindle from the cover and crown wheel shaft, using a rawhide hammer to prevent damage to the spindle. Remove the  $\frac{1}{8}$ -in. diameter key which prevents rotation of the spindle in the cover when tightening.

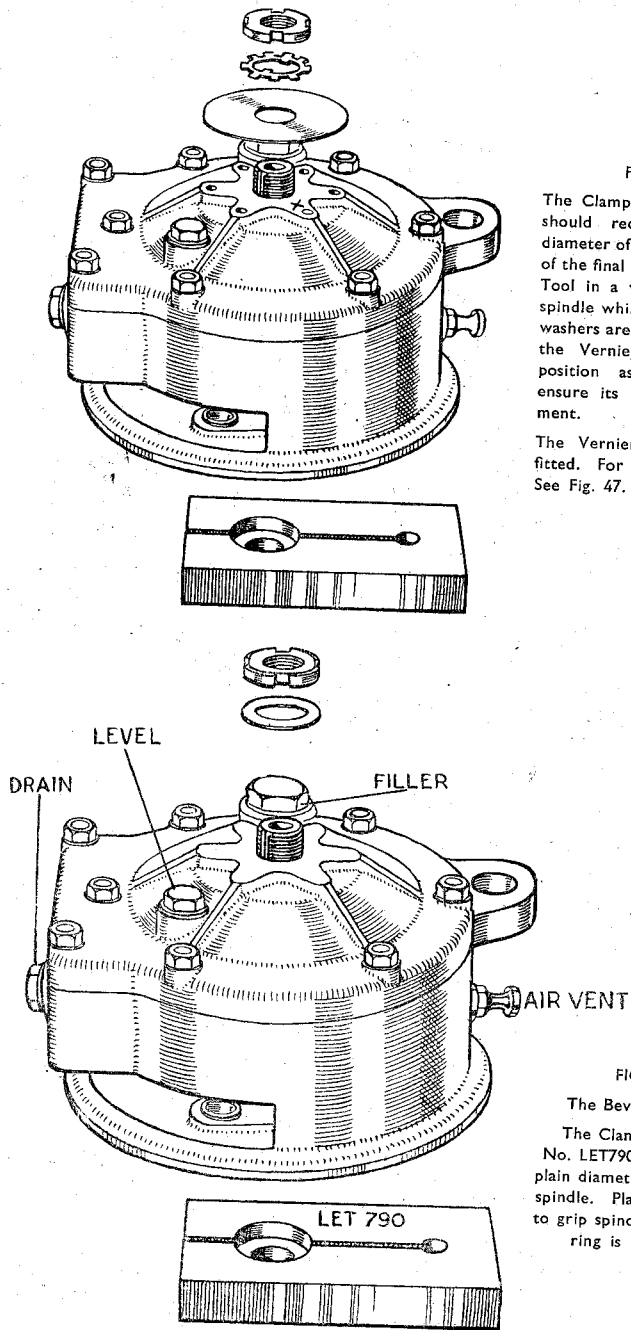

FIG. 46.

The Clamping Tool LET790 should receive the plain diameter of the fixed spindle of the final drive. Place the Tool in a vice to grip the spindle while lock ring and washers are removed. Mark the Vernier adjusting peg position as indicated to ensure its correct replacement.

The Vernier is no longer fitted. For current type—See Fig. 47.

FIG. 47.

The Bevel Casing.

The Clamping Tool No. LET790 receives the plain diameter of the fixed spindle. Place tool in vice to grip spindle while lock ring is removed.

## REMOVING THE CROWN WHEEL SHAFT FROM THE COVER.

Heat the cover, preferably by immersion in boiling water. Overheating, which may easily occur if a gas ring or jet is used, will cause distortion.

The expansion of the cover by heating will release the crown wheel shaft ballrace from the housing in the cover allowing the shaft and crown wheel to come away. Take out the oil seal housing with the oil seal. Be careful to retain any packing shims found between the ballrace and the oil seal housing. They must be kept for use when reassembling.

## REMOVING CROWN WHEEL SHAFT BALLRACE AND CROWN WHEEL.

Clamp the crown wheel shaft in a vice end-wise, using lead clamps over the jaws to prevent damaging the shaft and lever off the ballrace. Unscrew the six self-locking crown wheel nuts and remove the crown wheel.

## REMOVING THE BEVEL PINION ASSEMBLY FROM THE CASING.

A vice plate made to the dimensions in Fig. 48 is needed to hold the casing in the vice during this part of the work, and the special spanner LET781. The vice plate shown with the spanner is not supplied as a service tool, as it can be quite easily made from steel plate. The small sketch gives full details. Bolt the casing to the plate, using the cover nuts.

Support the casing by holding the plate in a vice, so that the splined end of the pinion points upwards as in Fig. 48 and unscrew and remove the bevel pinion assembly lock ring (Use lock ring spanner LET781).

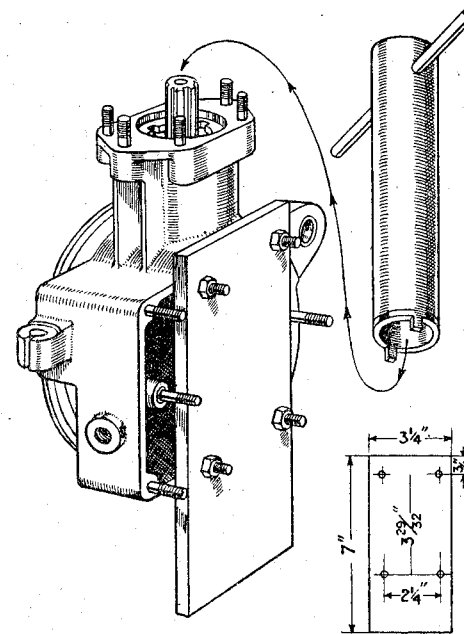

FIG. 48.

A Vice Plate mounted as shown and held in the vice while using Service spanner LET781 to remove bevel pinion lock ring.

Expand the housing by heating carefully and withdraw the bevel pinion assembly. Note whether any packing shims are fitted between the end of the pinion outer race and the casing. These may come out with the assembly or be left in place. Collect them carefully and preserve them for refitting if the same pinion is to be put back.

FIG. 49.

Vice Tool LET788 shown below the splined end of the bevel pinion shaft and service Spanner LET789 to be used for unscrewing the lock ring.

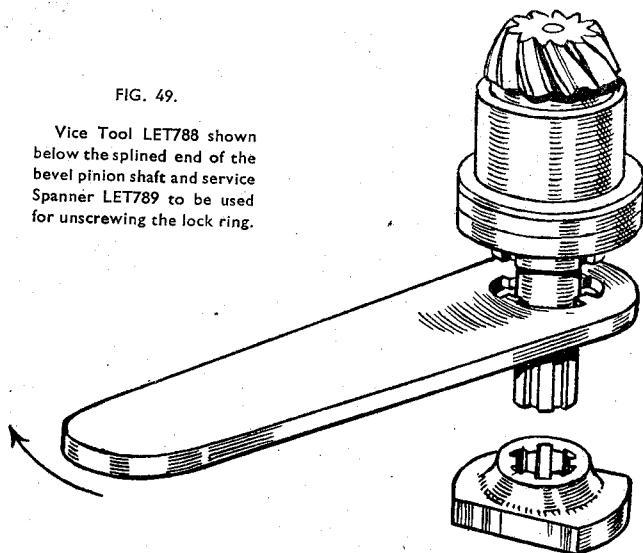

### REMOVING BEARINGS FROM BEVEL PINION.

Remove the oil seal with the oil seal housing from the pinion.

Place the vice tool (LET788) in the vice, and tighten firmly. Bend back the tab washer and fit the spanner (LET789) over the bevel pinion lock ring (See Fig. 49). Insert the splined end of the spindle in the vice tool and unscrew the lock ring with the spanner.

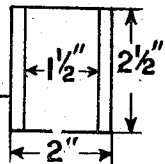
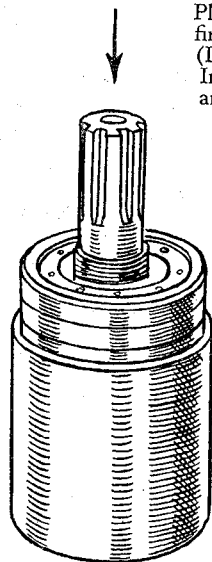

FIG. 50.  
A suitable Bush for use while pressing out the bevel pinion.

Lift the pinion out of the vice tool, and remove the lock ring and tab washer.

Obtain a suitable bush (Fig. 50) 1 1/2-in. internal diameter, 2 1/2-in. long and 1/4-in. radial thickness, i.e., 2-in. outside diameter. Place the bevel pinion outer race into the bush, and press the pinion from the ballrace. Remove the ballrace, the outer race, and collect the seventeen rollers.

### ASSEMBLING THE BEVEL PINION.

Replace the seventeen bearing rollers on to the roller track on the pinion, sticking them in place with a little light grease. Carefully fit the pinion outer race over the rollers, plain end first, so that the flanged end faces the splined end of the pinion. Make sure that the bevel pinion collar is in place against the shoulder of the roller track on the pinion. Fit the pinion ballrace, the tab washer and the lockring, making sure that the machined face of the locking ring is against the tab washer. Tighten the locking ring firmly, pushing the ballrace home on the pinion up to the pinion collar. Use the service tools LET788 and LET789. When the locking ring is tight bend a tongue of the tab washer into one of the serrations in the locking ring.

If a new oil seal is needed, tap out the old one from the housing and fit a new seal, using Service Tool LET 787 (Fig. 51).

Tool LET787 for the replacement of oil seals.

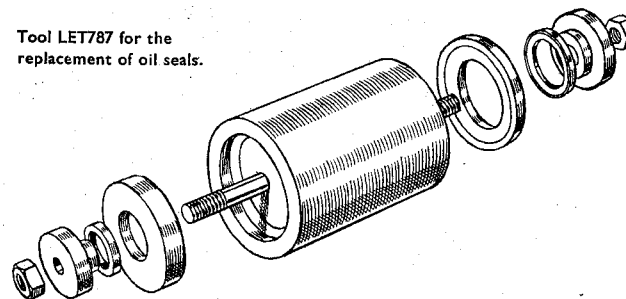

FIG. 51.

### REASSEMBLING ORIGINAL BEVEL PINION TO THE BEVEL DRIVE CASING.

This section deals with refitting a pinion which has been in use before on the machine. If a new pinion is being fitted for the first time refer at once to the next section.

Place in position on the outer race against the flange all the shims which were taken out when dismantling. Heat the neck of the bevel casing and drop the bevel pinion assembly into position, pressing it home by hand.

By means of the Vice plate previously mentioned, hold the casing upright as in Fig. 48, replace the bevel pinion assembly locking and tighten firmly with special spanner LET781.

### REASSEMBLING WITH A NEW BEVEL PINION AND CROWN WHEEL.

Place the bevel pinion assembly in the bevel pinion shimming fixture LET810 (Fig. 52) from the "cut away" end, entering the roller bearing outer race—with no shims on it—into the fixture as shown.

Rest the pinion assembly and fixture firmly on an accurate surface plate or against a straight edge, and press the splined end of the pinion to make sure that the head of the pinion is in contact with the face plate or straight edge.

It will be found that there is a small clearance between the underside of the outer race flange and the shimming fixture. Check the extent of the clearance by inserting feeler gauges through the cutaway portion between the flange and the ground face of the fixture, making sure that the pinion is in contact with the face plate or straight edge, as otherwise a false reading will be obtained.

Select packing shims to the exact thickness of the feeler gauges which were found to fit the gap between the outer race and the fixture.

Remove the pinion assembly from the fixture, fit the shims selected over the outer race and re-insert the assembly in the fixture. Check that the shims have completely taken up the clearance previously noted with the head of the pinion against the face plate or straight edge.

Reassemble the pinion assembly to the casing with the selected shims as described in the foregoing section.

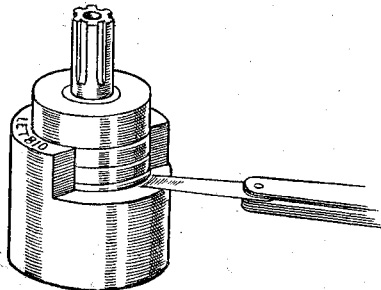

FIG. 52.

The Bevel Pinion Shimming Fixture No. LET 810 Feeler gauge is in use checking clearance.

### REASSEMBLING THE CROWN WHEEL.

The following procedure covers the replacement of the original crown wheel. If a new crown wheel and pinion are to be fitted see Page 57.

Fit the crown wheel to the shaft and secure it with the six crown wheel bolts, setting the bolt heads against the back face of the crown wheel and the self-locking nuts against the flange on the shaft. Make certain that the faces of the crown wheel and the flange on the crown wheel shaft are scrupulously clean before placing the crown wheel in position on to its register, as even the slightest trace of foreign matter between the faces will prevent the crown wheel running true.

If new nuts are needed it is essential only to use the genuine self-locking nuts and not in any circumstances substitute anything else.

Hold the shaft end-wise in the vice, protecting it from the vice jaws with soft metal clamps, and tighten fully the six nuts. Press on the ballrace to the shaft.

### REASSEMBLING THE CROWN WHEEL AND SHAFT TO THE BEVEL CASING COVER.

Fit the oil seal housing with the oil seal in it in place in the ballrace housing in the cover, and drop in the fixed spindle (inner) washer. Replace in the housing the packing shims which were removed and should have been kept aside carefully. The exact thickness of shimming is essential to proper meshing of the crown wheel with the pinion.

Heat up the cover, being careful not to overheat it, and quickly enter the crown wheel shaft ballrace in its housing and tap the shaft home.

See Page 57 if a new crown wheel is being fitted.

### REFITTING THE FIXED SPINDLE.

Pass the fixed spindle through the crown wheel shaft, and centralize the fixed spindle (inner) washer so as to allow the threaded end of the spindle to go through it into the cover, and tap the spindle home.

Hold the plain end of the spindle in the clamping tool (LET790) and secure the tool in a vice so that the cover is uppermost (Fig. 46). Do not overtighten. Turn the cover to register the key way groove in the cover with the groove in the spindle. Fit the  $\frac{1}{8}$ -in. diameter key and tap this down into the grooves until the end is flush with the face of the cover. Place the plain washer over the threaded end of the spindle, screw on the lock ring and tighten fully. Remove the clamping tool from the vice and take it off the spindle.

### REFITTING THE CROWN WHEEL SHAFT TO THE BEVEL CASING.

Place the bevel casing on the bench with the open side upwards, and fit the two locating dowels to their respective studs, *i.e.*, those in the counter bored holes in the casing. Fit the joint washer or a new one, sticking it to the face with light grease.

Stick the twenty-three bearing rollers in place with grease around the roller track on the crown wheel shaft.

Take up the cover and shaft, and enter the shaft with the rollers into the steel outer race in the bevel casing being careful not to displace any of the rollers in the process.

Locate the cover over the studs and with hand pressure only push it down firmly to the face. Fit the eight shakeproof washers, and the nuts and tighten down evenly a little at a time until fully tight.

### FITTING A NEW CROWN WHEEL.

The crown wheel is fitted to the crown wheel shaft as described previously and reassembly is carried out just as when fitting a crown wheel that has been used before except that it is necessary to mesh the crown wheel to the pinion with the correct backlash between the teeth.

As the exact thickness of packing shims which will be needed between the crown wheel ballrace and the oil seal housing to get the correct meshing is not known, it is advisable at the outset to rebuild the assembly with the same quantity and thickness of shims as used with the old gears.

Before refitting the crown wheel shaft and cover however, check roughly the position of the crown wheel ballrace in its housing in the cover. When fully home it is found that usually the face of the ballrace is just below the face of the housing by something like .005 -in. This can be seen quite easily by looking across the housing, under the back face of the crown wheel when the crown wheel shaft is assembled to the cover.

Refit the cover as described in the last section, but as the nuts are tightened down maintain a constant check on the pinion and crown wheel to find out if they are becoming tight due to meshing too closely.

At the first sign of tightness stop tightening the cover nuts and remove the cover and shaft from the bevel casing, for the crown wheel shaft to be removed and for shims to be taken out.

The cover must, of course, be heated again to free the ballrace, and .015-in. thickness of shims should be taken out and the crown wheel shaft etc. replaced and the cover refitted to the casing for further trial.

To help in turning the pinion the vice tool LET788 (Fig. 50) may be fitted over the splines.

The aim is to get the crown wheel and pinion to mesh with the least possible backlash consistent with silence and free running in all positions. Usually the backlash is about .005-in. If there is more than .005-in. backlash after fitting and tightening down the cover, packing shims must be added to the housing to take up the excess.

It is important to remember that every time the shimming needs to be altered, the cover, and crown wheel shaft, etc. have to be removed from the bevel casing, and the crown wheel ballrace removed from its housing. The cover must therefore be heated each time to get the ballrace out or to refit it. Failure to do this will scrap the cover. Without the use of most expensive apparatus it is impossible otherwise to remesh the gears, and the process described, which is one of trial and error, is one in which patience and skill play a major part. Finally, refit the fixed spindle, washer and lockring and tighten up.

#### FITTING THE BRAKE SIDE OIL SEAL.

Place the bevel casing assembly on the bench with the brake side uppermost.

Slide a new oil seal on to the thin sleeve of the service tool LET726 (Fig. 53) after lightly greasing the tool to prevent damaging the thin sealing edge of the rubber. See that the metal face of the oil seal goes on first so that it will enter the housing in the correct way, that is with the thin sealing edge towards the inside of the bevel casing.

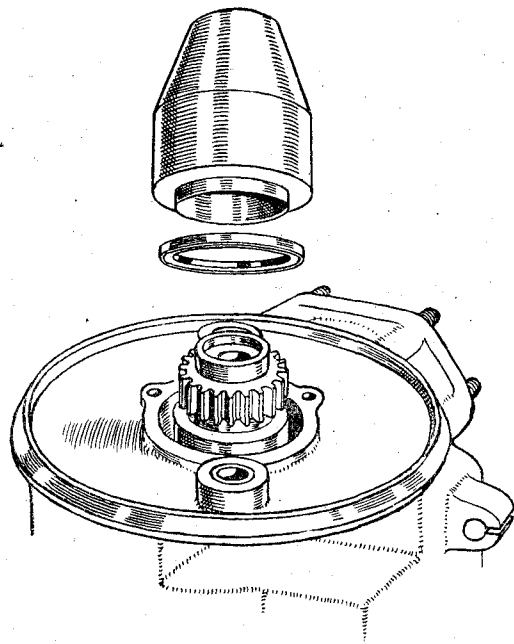

FIG. 53. Using the special Oil Seal Tool LET 726 for fitting the brake side oil seal.

Place the tool and the seal over the driving dogs on the crown wheel shaft and be careful to enter the seal correctly to the mouth of the housing in the casing.

Keep the tool square to the bevel casing whilst tapping the end of the tool gently to drive the oil seal into place. Continue tapping until the tool touches the face of the bevel casing.

**NOTE.** The bevel casing has now been modified to provide a collector for any oil which may get past the oil seal. The Service Tool LET963 must be used for housings of this type which are easily recognisable by the casing round the oil seal on the outside being circular (Fig. 54). With a half turn withdraw the tool. Refit the brake shoes and springs and refill the casing to the correct level with oil.

#### REPLACING BEVEL DRIVE OIL SEALS.

Leakage of oil into the rear brake may also be due to leakage past the bevel drive oil seal behind the crown wheel ballrace so that it is advisable to replace this seal at the same time as the oil seal mentioned in the previous section.

Drain the bevel gear casing, and dismantle the end cover, fixed spindle and crown wheel shaft, as described in the sections respectively dealing with these details.

Tap out the oil seal housing and oil seal, draw a new seal into position with the service tool LET787 (Fig. 51).

The bevel pinion oil seal is also dealt with using the same tool and is accessible after the removal of the bevel pinion assembly lockring and the pinion assembly (See Page 53).

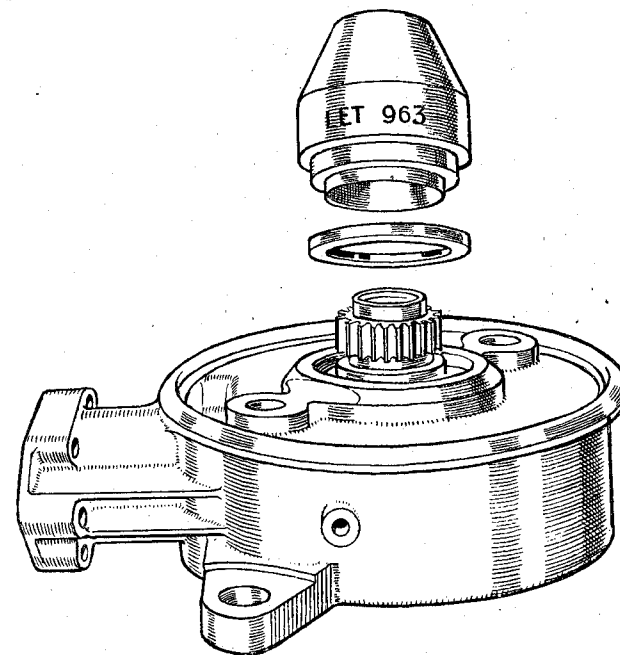

FIG. 54. Using the Special Oil Seal Tool No. LET 963 for fitting oil seal to bevel casing

#### REPLACING THE UNIVERSAL JOINT ASSEMBLY.

This replacement may be made without completely removing the frame.

Place the machine across a trestle or stout box, resting it on the engine unit with the wheels overhanging the edges. If a box is used be careful that the machine does not overbalance forward as the frame is lifted up from the rear.

Unscrew and withdraw the rear wheel spindle, catching the distance piece from between the hub and the fork end, and remove the rear wheel. It may be necessary completely to slacken off the rear brake cable adjustment before the wheel will come off.

Slip the cable nipple out of the shackle, screw out the adjuster, and pass the cable through the slot in the adjuster boss.

Support the rear fork assembly and remove the two nuts from the top ends of the rear spring struts. Lower the fork assembly gently. Disconnect the feed pipe from the carburetter.

Remove the two  $\frac{3}{8}$ -in. nuts and bolts (one at each side) holding the tops of the legshields to the frame, and the upper bolt of each pair holding the tubular frame assembly (Fig. 55). Slacken off but do not remove the lower bolts. Remove the gear lever knob.

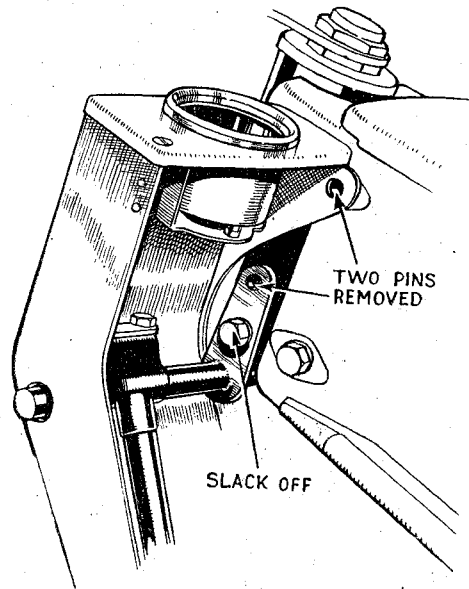

FIG. 55.

Removal of the two Upper Pins and Nuts, and the slackening off of the two lower pins on either side, to allow the frame to pivot when lifted from the rear.

Unscrew the gear lever off the gear lever end and draw it away through the slot in the frame.

Remove the four bolts (two at each side) from the lower part of the frame immediately above the rear portions of the footboards, catch the "C" nut plates as they are pulled out (Fig. 3). Turn the handlebar to full lock either way.

By taking hold of the rear mudguard and raising it carefully the frame will pivot on the two bolts which were slackened but left in place at the front end.

Raise the frame until the flanges of the rear fork hinge pins are exposed, and withdraw these by twisting the flanges and pulling them outwards. A gentle tap will move them if they are more than hand tight.

Stand behind the machine and lift the rear fork to a horizontal position and pull away to the rear. Do this gently, so as not to damage the felt rings. Take care of the large felt ring at the ball end of the rear fork where this meets the rear cross member.

The rear fork bell may be removed from the fork by levering it out, allowing the Universal joint assembly to be withdrawn.

Smear the splines in the new coupling with graphite grease, and push it on to the propeller shaft, making sure that the propeller shaft is properly engaged with the muff coupling at the rear, and the muff coupling on the splined end of the bevel pinion.

Refit the rear fork bell and tap it into place, using a rawhide hammer. Replace the large felt ring in position. Cut two discs about 2-ins. diameter from .010-in. thick pen steel. Place these over the pivot ends of the rear fork to retain the two felt rings, and prevent them being damaged (Fig. 56).

Hold the rear fork horizontal and push it forward into place inside the rear frame cross member, engaging the universal joint splines with those on the end of the gearbox secondary shaft. With a little pressure the fork will slide back into place.

Remove the steel discs protecting the felt rings and refit the two hinge pins.

Lower the frame into position, refit and tighten all the bolts removed or slackened, refit the petrol pipe and rear wheel.

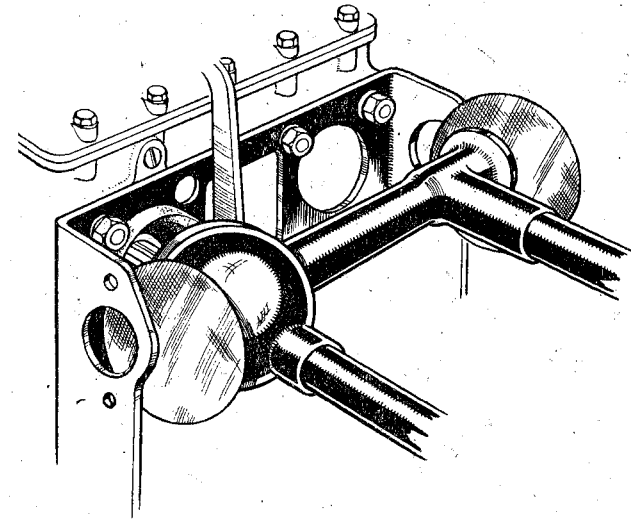

FIG. 56.

Two Pen Steel Discs placed over the pivot ends of rear fork to prevent damage to felt rings while assembling.

#### REPLACING FLYWHEEL HOUSING OIL SEAL.

This replacement may be made by removing the generator and flywheel from the engine.

The need for replacement will be shown by oil draining into the flywheel housing, and if the leakage is excessive the oil may get into the generator.

Remove the generator and the flywheel as described in two later sections (Pages 63 and 65) observing the precautions advocated to prevent the permanent magnets in the generator (if a B.T.H.) from picking up iron and steel filings, etc., off the work bench. If a Miller generator, place "keepers" across the permanent magnets in the flywheel to prevent deterioration of the magnets whilst the stator plate is out of place, or replace the stator plate in the flywheel as soon as the flywheel is taken off.

The removal of the flywheel will disclose the oil seal housing held to the flywheel housing by three 2BA pins. Remove these pins, and the oil seal housing containing the oil seal.

Remove the old oil seal with its housing and the joint washer.

Examine very carefully the boss of the flywheel, which runs in the oil seal, for any scratches or bruises, and if needed polish it up very carefully.

The finish of the boss is very important, as the efficiency of the oil seal depends on it being smooth and true. Be most careful to see that if much polishing has to be done the diameter is not reduced below 1.245-in. Thoroughly wash out the flywheel housing with petrol and dry off. Take the old oil seal from its housing and insert the new one.



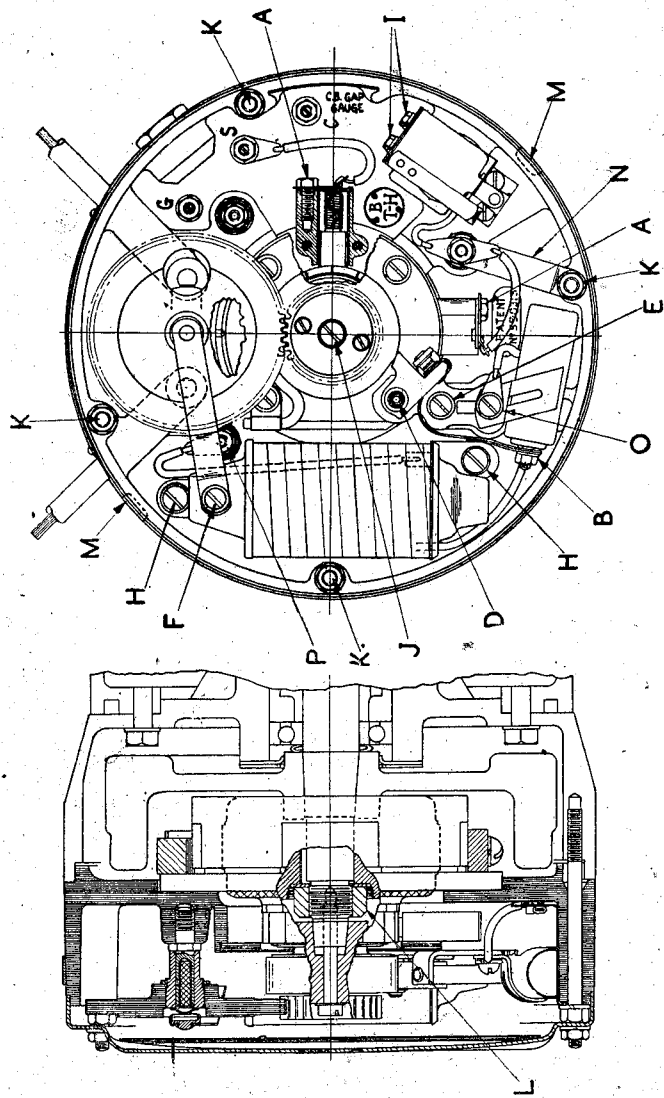

FIG. 57.

Sectional drawing of Type PEC Unit giving reference letters for the various parts.

Smear the oil seal housing face, and the joint face on the flywheel housing with jointing compound and refit the gasket (or a new one) and the housing, and screw in the fixing pins just finger tight.

Slide the special bush LET793 (Fig. 30) on to the taper of the shaft to centralize the oil seal and tighten the three fixing pins. Remove the bush when the housing is secured.

#### REMOVING THE GENERATOR (B.T.H.).

**Disconnect the leads to the battery.** From below the switch panel, detach three wires marked Red, Green and Black by separating at the "jacks."

Remove both high tension leads from the sparking plugs. Remove the front cover by taking off the four fixing nuts and shakeproof washers from around the edge and pulling off the cover (Fig. 57).

Take off the contact blade by the removal of screw F from the top of the coil, and pull the distributor gear off its spindle. Remove the fixing screw J from the end of the flywheel shaft, screw into the cam the cam extractor screw, tighten the screw, until the cam and automatic timing unit are released as an assembly from the shaft. Use LET801 (Page 50)

Remove four nuts and washers from studs K and, with special spanner (Fig. 39) the nut and washer L holding the armature to the flywheel shaft. To prevent the crankshaft turning when loosening this nut, engage low gear and apply the rear brake, or "chock" the crankshaft.

Screw into the centre of the generator the extractor tool LET646 (Fig. 58). Loosen the moulded body of the generator assembly from its spigot in the flywheel housing by inserting a screwdriver in the slots M and lever the body away until there is a gap of about  $\frac{1}{8}$ -in. Then ease the armature forward off the shaft for about the same distance by tightening the centre screw of the extractor tool.

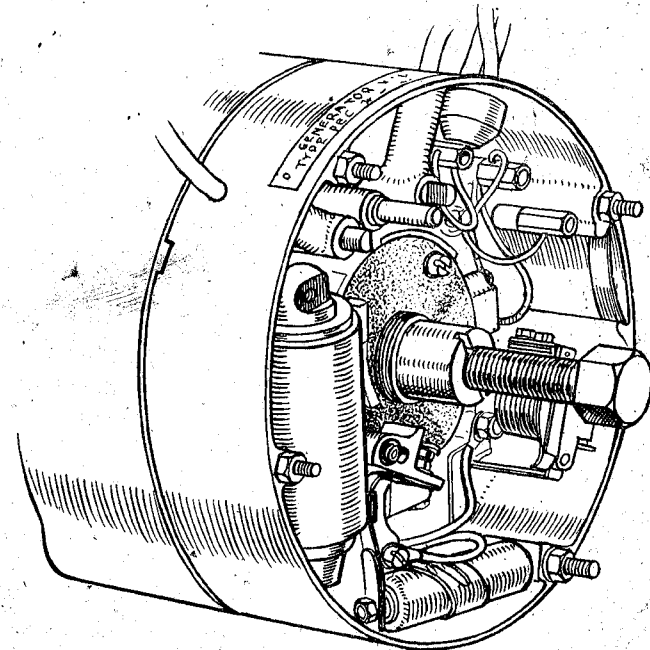

FIG. 58. Showing the Generator Extractor Tool LET 646 in position. Read the instructions for this task very carefully or damage will be done.

Alternately ease forward the body along the studs and the armature off the shaft until the whole assembly can be withdrawn by hand, taking care not to lose the key from the flywheel shaft.

As soon as the generator is taken off place it in a clean box well away from the work bench or anywhere where there may be filings or metal particles which would be attracted by, and stick to the permanent magnets in the generator.

### REMOVING THE FLYWHEEL (B.T.H. GENERATOR).

Having removed the generator, screw on to the end of the flywheel shaft the protector LET647/1 (Fig. 59). This must be used to prevent damage to the taper at the extreme end of the shaft when tightening the extractor screw.

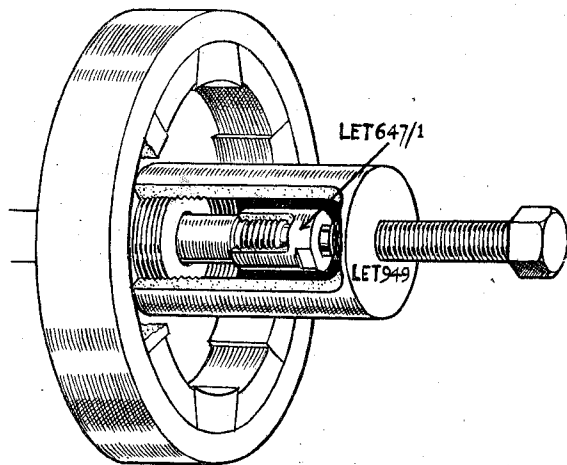

FIG. 59. Drawing Flywheel from Flywheel Shaft.

Illustration shows Service Tool No. LET 949 for Miller Flywheel with Protector No. LET 647/1 on end of shaft.  
For B.T.H. Flywheel use Service Tools Nos. LET 647 and LET 647/1.

Screw the extractor LET647 (Fig. 59) on to the threaded boss of the flywheel. Engage bottom gear, hold on the rear brake, and tighten the extractor centre bolt until the flywheel is released from the taper on the flywheel shaft.

If the engine unit is out of the frame, the crankshaft may be held either by engaging two gears at once, or by "chocking" the crankshaft with a block of wood—both methods have been explained previously (Pages 14 and 31).

Detach the extractor and protector and remove the flywheel. Note specially when putting the flywheel aside that the boss at the rear which runs in the flywheel shaft oil seal is protected from damage whilst the flywheel is off.

### REFITTING THE GENERATOR (B.T.H.)

Push the moulded generator body carefully over the studs and at the same time fit the armature over the flywheel shaft engaging the keyway in the centre over the Woodruff key in the shaft, see note Page 65. Fit the nut and tighten down securely with special spanner (Fig. 39), at the same time pushing the generator body back into place against the face of the flywheel housing. Fit and tighten the four nuts securing the generator body in place.

Retime the ignition as explained on Page 50.

Refit the contact blade to the coil and see that it bears on the centre of the distributor gear. Be very careful not to bend this strip so as to cause it either to press too hard on the gear, or fail to make proper contact.

Finally, refit the cover. Connect up the lighting cables to the switch panel, checking the coloured collars, connect the battery (note positive cables to frame or "earth") and refit the leads to the sparking plugs.

**SPECIAL NOTE.** Should the armature be tight and go on, when pushed by hand, only far enough to start the nut for a few threads do not in any circumstances tap it or drive it on, as it is easily damaged and would be ruined by such treatment. Pull it up by tightening the nut carefully until fully home.

### REMOVING THE GENERATOR AND FLYWHEEL. (Miller Types A.C.3 and A.C.3P).

To remove the generator take off the two nuts holding the large circular cover to the generator.

Take out the centre bolt securing the timing unit to the flywheel shaft. Screw the extractor bolt LET948 into the unit (Fig. 46). Tighten down until the unit is free of the taper and take it off. Remove the extractor bolt from the unit.

### REMOVING THE STATOR PLATE ASSEMBLY. (Miller)

Unscrew and remove the four nuts holding this to the flywheel housing. Two are on the long studs which also hold the circular cover, and two are situated on shorter studs near the edge of the stator plate, about midway between the others.

Disconnect the lighting and ignition leads at the "jacks" or connectors below the switch panel on the right-hand side. Detach the sparking plug leads at the plugs.

Pull the stator plate assembly forward carefully off the studs and take away.

### REMOVING THE FLYWHEEL. (Miller)

#### SPECIAL NOTE.

The flywheel is carefully fitted to the crankshaft during initial assembly so that the relative positions of the moving and stationary pole pieces of the generator at the moment the contact breaker points separate give the maximum intensity of spark. This angle is very critical and it is essential that when the flywheel is replaced it is correctly set. To enable this to be done easily the Service Tools LET952 and LET953 are supplied (Fig. 70). If these tools are not to hand the flywheel should be left undisturbed if at all possible, but as removal may be necessary when the resetting tools are not available, directions for resetting the flywheel without their help are given on Page 67.

To remove the flywheel, first secure the crankshaft from turning by inserting a block of wood between the flywheel shaft balance weight and the inside of the crankcase. The method is shown in Fig. 27, but in the sketch the block is illustrated against the driving shaft balance weight. When removing the flywheel see that the block is against the forward balance weight, otherwise the crankshaft alignment may be deranged.

Unscrew and remove the flywheel nut, using the spanner shown (Fig. 39) and pull off the distance piece behind it. Screw on to the front end of the flywheel shaft the Protector LET647/1 (Fig. 59).

Screw on to the flywheel boss the Extractor LE949 (Fig. 59) and tighten down the centre screw to draw the flywheel off the taper on the shaft. Remove the flywheel extractor when the flywheel is freed, take off the protector from the shaft, and take away the flywheel. Place steel "keepers" over the open side of flywheel.

Whilst the flywheel is off see that it is put away carefully where there are no steel or iron particles which could be attracted by the magnets and stick to the flywheel. Also take great care not to damage the accurately ground boss at the back of the flywheel, as this runs in the flywheel housing oil seal, and if scratched or bruised will cause oil leakage past the seal.

If necessary this oil seal may be replaced whilst the flywheel is off. For directions for doing the work see Page 61.

### REFITTING THE FLYWHEEL (MILLER).

As explained in the special note at the beginning of the preceding section, the flywheel must be set in correct relation to the crankshaft.

The best method is to employ the flywheel setting block LET953 and the flywheel setting plate LET952 and the procedure when these tools are available will be described first, and directions for doing the job another way will follow.

Remove the wood block securing the crankshaft. Remove the left-hand cylinder head, and gasket. (Should the flywheel be being fitted to an engine in a partly dismantled state before the cylinders and pistons have been fitted, fit the left-hand piston, and cylinder in place temporarily). Attach the flywheel setting block LET953 to the cylinder by using two of the cylinder head nuts. This locates the piston which when in firm contact with it ensures that the crankshaft is in the correct position for the flywheel to be fitted (Fig. 70).

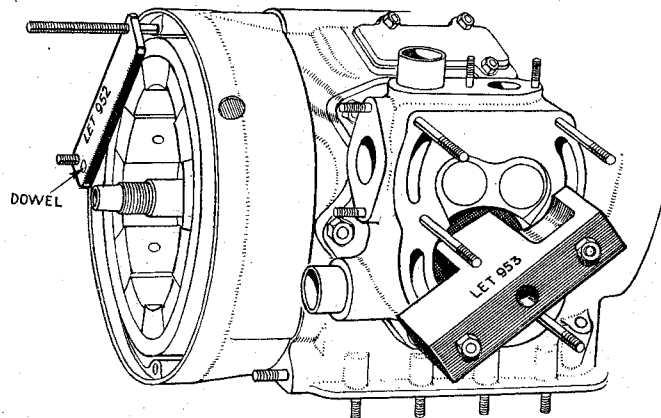

FIG. 70.

Service Tool No. LET 952. Miller Flywheel Setting Plate.  
Service Tool No. LET 953. Miller Flywheel Setting Block.

Setting plate is shown locating flywheel and the setting Block fitted to cylinder.

Clean the taper on the flywheel shaft, and the taper in the flywheel, and see that the oil seal boss at the back of the flywheel is clean and undamaged. If scratched or marked clean it up as described on Page 61, being careful not to reduce it below 1.245-in. diameter. See that no metal particles are stuck to the magnets.

Place the flywheel carefully in position on the taper, leaving it free to turn. Fit the flywheel setting plate LET952 over the top and right-hand side studs in the flywheel housing, and at the same time locate the dowel on the plate in the dowel hole bored in the front face of the flywheel rim (Fig. 70). Make certain that the piston is in firm contact with the setting block and push the flywheel firmly on to the taper and fit the distance collar and flywheel nut. At this stage tighten the flywheel nut only enough to keep the flywheel from moving on the shaft whilst the setting tools are removed and the wood block replaced against the flywheel shaft balance weight. **Do not in any circumstances try to tighten the nut fully with the setting tools in place.** They must not be used to hold the crankshaft against the force applied to the spanner.

After removing the setting tools secure the crankshaft by the wood block and tighten up the nut fully. If this is done carefully the flywheel should not move on the taper, but if thought advisable the setting tools may be replaced and the location checked.

### TO REFIT A FLYWHEEL WITHOUT THE SETTING PLATE AND BLOCK. (Miller)

First set the left-hand piston exactly at top dead centre. Clean the taper on the shaft.

Remove the "keepers" from the flywheel and see that it is entirely free from any metal particles attracted by the magnets, and that the internal taper and the oil seal boss at the back are quite clean.

Put the flywheel on to the taper with the dowel hole set as nearly as possible at "12 o'clock" and fit the distance piece and flywheel shaft nut. Do not tighten the nut but run it up the thread just enough to keep the flywheel in place but free to be turned on the taper.

Carefully place the stator plate assembly into position on the studs without moving the flywheel or the crankshaft, and push it fully home.

At "12 o'clock" in the stator plate there is a  $\frac{1}{2}$ -in. diameter hole through which, if the flywheel has not been moved, it will be possible to see the dowel hole in the flywheel rim.

With the piston held exactly at top dead centre the dowel hole must be exactly in the centre of the  $\frac{1}{2}$ -in. hole. If it is not, hold the piston at top dead centre and push the flywheel round in the direction required to centre the hole, by means of a small bar or spoke passed through the  $\frac{1}{2}$ -in. hole and engaged with the dowel hole.

As it is always possible to move a crankshaft a degree or so without moving a piston at top dead centre, see that the flywheel is set so that the few degrees of lost motion are from the centre of the  $\frac{1}{2}$ -in. hole to the left when facing the stator plate, i.e., anti-clockwise. (Fig. 45).

Having set the flywheel, draw off the stator plate assembly most carefully, so as not to move the flywheel, and partly tighten the nut. As soon as the flywheel is held on the taper replace the stator plate assembly temporarily and check the setting. If satisfactory remove the stator plate assembly again and finally tighten the nut.

### REFITTING THE STATOR PLATE ASSEMBLY. (Miller)

Push the stator plate assembly into position. Clean the flywheel shaft taper and the internal taper of the timing unit. Fit the timing unit loosely on the taper with the centre bolt in position. Retime the ignition (See Page 50) and finally refit the cover and connect up all electrical cables.

## THE FRONT FORK — REMOVING A FORK STRUT ASSEMBLY.

A single strut assembly may, if desired, be removed for attention without disturbing the handlebar, headlamp or mudguard. To remove one strut place the machine across a trestle, resting on the engine unit with the wheels overhanging the sides.

If working on the right-hand (brake side) strut, disconnect the brake cable from the shackle, and screw the adjuster out of the fork end (Fig. 62). Remove the front wheel. Take off the nut and washer securing the handlebar to the top of the right-hand strut.

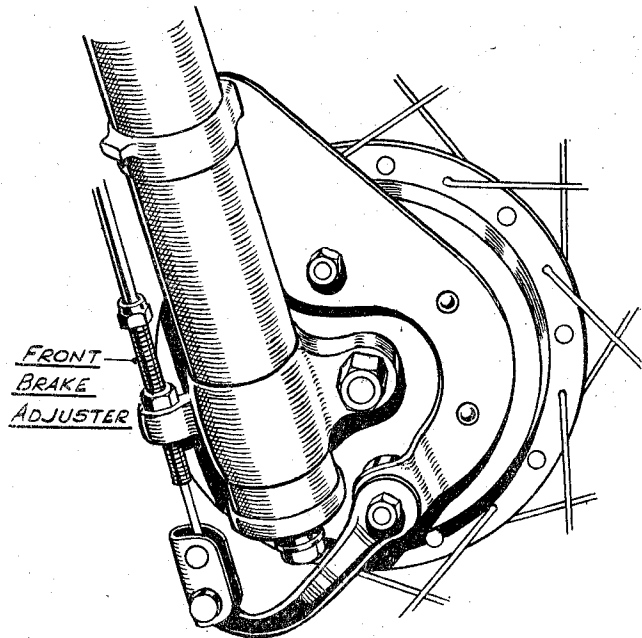

FIG. 62.

Screw off the fork lock ring from above the bottom cross piece of the steering column with the spanner LE480 from the tool kit or the service-tool LET783 (Fig. 60). Using a rawhide hammer, tap out the strut assembly from the top and thread it out through the mudguard.

## THE FRONT FORK. DISMANTLING THE STRUT ASSEMBLY.

Hold the strut upright to retain the oil and slide off the long tubular dust cover. Release the spring by holding the top part of the strut in one hand and twisting the spring anti-clockwise with the other. Next screw out the spring from the slider tube assembly.

To remove the slider tube assembly from the main tube assembly, hold the top of the tube assembly in one hand, and the slider tube assembly in the other and twist the two sections apart smartly. Repeat this until the slider bush is extracted from the slider tube. Having separated the two main parts of the fork the circlip may be sprung out of the groove at the bottom of the main tube and the bottom bush and the slider bush drawn off the tube.

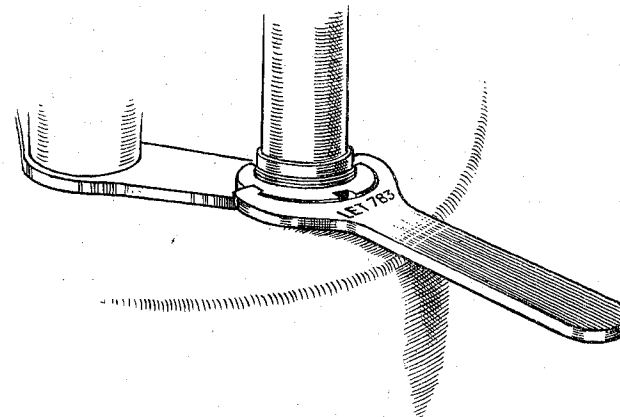

FIG. 60. Service Tool No. LET 783 Fork Lock Ring Spanner.

## THE FRONT FORK. REBUILDING THE STRUT ASSEMBLY.

Slide the spring on to the fork tube and screw it into the spring holder. Thread on the slider bush and press the fork tube bush into place, refitting the circlip in the groove.

See that the inside of the slider tube is clean, and then whilst holding it upright pour in  $\frac{1}{2}$ -pint oil (viscosity SAE30). Still holding the slider tube assembly upright, enter the bushed end of the fork tube into the slider tube. Rest the whole assembly on a pad or wood block on the floor and attach the split collar LET796 (Fig. 61) around the fork tube between the lower end of the spring and the slider tube bush.

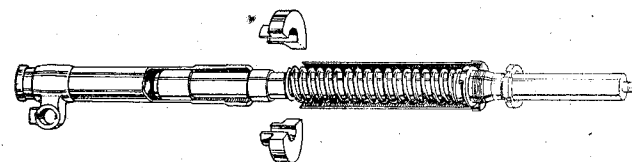

FIG. 61. Front Suspension System. The Split Bush LET796 is for use in forcing the Bush on the Fork Leg into position.

Lift the whole assembly, and bring it down smartly on the pad or block repeating the movement until the top bush has been forced fully home in the slider tube. Engage the spring with the bottom fixing and with the fork end lug at the bottom held in a vice and the strut still upright twist the spring fully home.

## THE FRONT FORK. REFITTING A STRUT TO THE MACHINE.

Slide the tubular dust cover down over the spring, and push the strut assembly up through the mudguard and cross piece of the column. Place the locking ring over the top of the strut, and push the strut upwards so that the threaded end at the top goes through the holes in the top fork cross member, and handlebar. Screw on the locking ring, and refit the washer and nut to the handlebar. Do not fully tighten.

Set the fork end over slightly towards the right, and not pointing exactly straight ahead and tighten the handlebar nut and locking ring fully tight. The purpose of setting the sliders over slightly in this way is to insure that when they are brought into alignment by fitting the wheel, there is a slight twist on the springs tending to keep them firmly wound into the spring seatings. Replace the front wheel.

#### REAR SPRINGING. ADJUSTMENT FOR LOAD.

Two identical spring units or legs support the machine at the rear and are connected to the swinging rear fork at the bottom ends and are held in slots in the rear mudguard at the top.

The rear suspension system is adjustable for different loads by altering the angle of the struts to the swinging rear fork. This is done by adjusting the top fixings to the desired positions in the slots in the mudguard. Both struts must, of course, be set to the same relative position in the slot. The position of the struts for light loading is fully forward, and for the heaviest loading, fully back (Fig. 42).

#### REAR SPRINGING. REMOVING THE STRUTS.

With the machine on a trestle resting on the engine unit both struts may be removed together, but they may be dealt with one at a time with the machine resting on the central stand.

Unscrew and remove the long fixing nut holding the upper end of the strut in the slot in the rear mudguard. If both struts are being removed at once, support the rear fork assembly, as otherwise it will drop down heavily when the nuts are removed.

Take out the bolt attaching the bottom of the strut to the bevel casing or the fork end as the case may be. Take care of the hardened sleeve which is fitted into the bush. The unit will now come away.

If the struts and springs are not very dirty they may be lubricated by smearing graphite grease in between the coils of the springs to prevent squeaking, and a little light oil (Viscosity SAE10) poured into the open end of the upper or larger tube to lubricate the bushes.

Should they be very dirty, however, they should be dismantled for cleaning.

#### REAR SPRINGING, DISMANTLING THE STRUTS AND REASSEMBLING.

Grip the lug in a vice and twist the spring anti-clockwise out of its seating. Repeat the process to free the other end of the spring. Pull out the damper strut assembly from the tube assembly and remove the spring (Fig. 63).



FIG. 63.  
Rear Suspension Strut.

To take off the bush the retaining circlip must be sprung out of its groove in the damper strut, after which the bush can be driven off.

To remove the rear spring fixed lug and the spring seat from the damper strut assembly, hold the spring lug in the vice, protecting it with soft clamps, and insert a tommy bar through the hole in the strut just above the bush. Unscrew the strut anti-clockwise.

Before reassembling lubricate the bush liberally with graphite grease and also smear all over the outside of the damper tube before fitting the spring.

Reverse the order of dismantling to reassemble the spring unit and refit to the machine with the fixed lug at the bottom.

#### THE RADIATOR AND COOLING SYSTEM.

The water in the radiator will not evaporate quickly in normal use but will need adding to occasionally and as found necessary. Never use hard water, which leaves deposits in the radiator and water jackets and will in a short while reduce the efficiency of the system. Clean rain water is probably the best. After refilling, and while the engine is warming up some water may run down the radiator overflow pipe owing to the expansion of the water on being heated, but the overflow will stop when the usual working temperature is reached.

This also accounts for the use of water being apparently excessive even after a short run, as a check of the water level when the water has cooled again will show a reduction in level a little greater than was perhaps expected. After a little experience it will be observed that the radiator need not be filled right to the top.

#### THE RADIATOR AND COOLING SYSTEM. PROTECTION DURING COLD WEATHER.

In conditions where the temperature is often or even occasionally below freezing point, precautions must be taken to prevent damage to the cylinder jackets and radiator due to the freezing of the water in the system. Careful storage in a warmed place may be effective in certain circumstances in the British Isles, but overseas in territories where temperatures are normally very low for long periods at certain seasons of the year an anti-freeze mixture should be used.

A satisfactory mixture is made by mixing soft water with either Inhibited Ethylene-Glycol, or Smith's Bluecol. The cooling system holds 2½ pints. The following are recommended.

A 20% mixture of Inhibited Ethylene-Glycol, or Bluecol ½ pint. Alternatively, a mixture of glycerine and Silicate of Sodium (Waterglass) in the proportions of ½ pint Glycerine, 2 drams Silicate of Sodium, with soft water to make up 2½ pints.

The former mixture will give protection against 35° of frost F. The latter up to 26.2° of frost F.

Before refilling with anti-freeze mixture drain off all the water by removing the cylinder head drain plugs, and flush out the radiator and water jackets thoroughly. Replace the drain plugs.

Mix up the anti-freeze with an equal quantity of soft water and pour into the radiator. Fill up to the usual level with more soft water. Start up the engine and run until hot to mix the solution thoroughly. All topping up of the radiator should be with a similar mixture, otherwise the efficiency of the mixture as a safeguard against frost damage will be reduced.

If a machine has to be left in conditions when freezing may be expected, and an anti-freeze mixture is not being used, drain the system at once. Leave the radiator filler cap on the saddle of the machine as a reminder to refill before using the machine again.

#### SPECIAL NOTE.

When the last drop of water has been drained off from both cylinders refit the drain plugs.

#### ROAD WHEELS, REMOVAL AND REPLACEMENT.

To remove the front wheel raise the front of the machine and place a box, block or something else suitable under the engine unit to keep the wheel clear of the floor. Push up the brake cam lever, slip the cable nipple from the shackle. It may be necessary to slacken off the adjustment to do this.

Loosen and remove the spindle nut from the brake end of the spindle. Loosen the spindle clamping bolt in the left-hand side fork end. Support the wheel and pull or tap out the spindle. Remove the wheel and brake assembly.

To take out the rear wheel, rest the machine on the central stand, loosen and unscrew the rear spindle and pull it out towards the right-hand side of the machine, catching the distance piece between the wheel and the fork end as the spindle comes away.

Pull the wheel sideways away from the final drive casing until the driving splines are disengaged. It will now come clear and can be removed from below the mudguard if the machine is tilted over a little to the left to give clearance.

**N.B.** On machines which have run several thousands of miles it may be necessary to slacken off the rear brake cable adjustment in order to get the wheel clear of the brake shoes. This is due to the fact that after prolonged use the brake linings will have worn a track of larger diameter in the brake drum and since the brake will be adjusted to this larger diameter it will be impossible to draw the unworn and therefore smaller diameter mouth of the brake drum over the brake shoes.

To replace the front wheel push the wheel into place between the fork ends, engaging the forked brake anchor with the brake stop peg on the fork end. The fork ends may have to be sprung back a little against the springs to enter the wheel, as in assembling the fork it is usual to leave the sliders set a little off the straight and towards the right, so as to keep a twist in the springs when the wheel is in place, and thus hold the springs firmly in their seatings.

Push the spindle back into position through the fork ends and the hollow spindle of the hub from the left side towards the brake side.

Replace the spindle nut and tighten securely. Replace the brake cable and readjust the brake if needed. Remove the support from below the machine, and with the front wheel resting on the floor push and pull the front of the machine down and up to insure freedom of working in the fork struts, and finally retighten the spindle clamping bolt in the left-hand fork end.

To replace the rear wheel tilt the machine over to the left and roll the wheel into position under the mudguard, and raise it into position on to the driving splines engaging these by a semi-rotary backwards and forwards motion. Place the distance piece in position between the hub and fork end and pass the spindle through the fork end, distance piece, and hub, and tighten it up.

If the brake adjustment has been altered, re-adjust, and check wheel for freedom when brake is "off."

## WHEEL BEARINGS. DISMANTLING AND RE-ASSEMBLING.

Both wheels are fitted with non-adjustable ballraces. If these develop too much play they must be removed and replaced.

As the construction of both wheel hubs is identical, the following directions apply to both front and rear hub assemblies. The brake assembly must, however, be taken out of the front hub after removing the wheel from the machine.

If the hubs are being dismantled just to repack the bearings with grease and if the ballraces are in good condition there is no need to remove the brake side ballraces. The hubs can be repacked easily after removing the hollow spindle and the ballrace remote from the brake. The work of dismantling in such circumstances need only be carried as far as indicated in the following directions.

To remove the bearings lever off the dust cover, unscrew the hub lock ring, using the lock ring spanner LET781 (Fig. 48), and take out the ring and grease retainer, which is behind the ring.

As the lock rings are usually very tight it is recommended that the spanner be held firmly in the vice working end upwards, and the wheel placed over it so that the spanner engages with the lock ring. The wheel can then be turned relative to the spanner and the large amount of leverage gained in this way will free the most stubborn ring. Also use this method when refitting.

With a soft metal drift, drive out the hollow spindle from the brake side towards the side from which the locking ring was taken.

**NOTE.** Proceed no further than this if only repacking with grease is needed, and the brake side bearing is in good order. Use only a high melting point grease for repacking.

Using a soft drift again, this time applied to the inner ring of the brake side ballrace, drive out the ballrace the same way as the hollow spindle was removed. The hub distance tube will come out first and should be taken away. After moving the ballrace into the hub for about  $\frac{3}{4}$  of an inch it will clear the ballrace housing and drop loosely into the barrel of the hub, which is of larger diameter than the ballrace housing. The ballrace must now be centralized and entered into the other ballrace housing, and tapped through it and out of the hub. The remaining grease retainer will now easily come out.

To replace the bearings place the wheel on the bench with the brake drum resting on a flat surface. Fit the grease retainer into the brake side ballrace housing convex face downwards (depressed side uppermost).

Fit the ballrace, or a new one, into the housing in the hub, and with a soft punch and hammer drive it through the housing and into the barrel of the hub. Centralize it with the housing at the brake drum side, see that it is quite square with the housing, and drive it home, nipping the grease retainer in between it and the end wall of the housing.

Push in the distance piece. If the ballrace has not been taken off the hollow spindle, push the spindle and ballrace into place, entering the end of the spindle in the ballrace on the brake side and the other ballrace in the mouth of the hub.

Using the drift as before, drive the hollow spindle and ballrace home.

Should the ballrace have to be renewed, the old one will first have been pressed off the hollow spindle, and a new one pressed on up to the shoulder before refitting the spindle.

Refit the second grease retainer, this time with the depressed face downwards towards the ballrace. Screw in the locking ring (also fitted with its recessed face downwards) and tighten up fully. Fit the dust cover assembly over the end of the hollow spindle and tap it down against the ballrace. The wheel is now ready for refitting to the machine.

## ROAD WHEELS—SPOKES.

Occasionally examine the wheels for loose or broken spokes. A loose or broken spoke will cause extra tension on the remainder, and can cause breakages of other spokes, rapidly making matters worse by still further overloading the spokes which are left to carry the load.

Therefore take steps immediately to tighten any loose spokes or replace any that are broken as soon as the necessity arises.

If any new spokes are to be fitted, first remove the tyre, tube and rim-band so that after fitting the new spoke any part of the threaded end which projects beyond the nipple into the well of the rim may be cut off and filed flush with the nipple. If this precaution is not taken the inner tube will be punctured by the end of the spoke.

## BRAKES.

The brake drums and linings require cleaning from time to time, and the wheels should occasionally be taken out and the brakes examined.

Any oil, grease, or moisture on the friction surfaces will impair the braking efficiency.

If new linings are needed, make sure that they are of the correct type. New linings and rivets are supplied separately.

Alternatively, new brake shoe assemblies can be obtained. Each brake shoe assembly consists of a shoe with lining and rivets fitted.

### TYRES. CARE AND MAINTENANCE.

To obtain the best service from the tyres, careful attention should be paid to inflation. More tyres are probably ruined through under inflation than by fair wear and tear. Check the pressures about every 500 miles running, or if the machine is not used regularly check weekly. The **minimum** pressures advised are given on Page 5. Note that additional loading, a pillion passenger for instance, demands increased pressure.

Occasionally, inspect the tyre treads and remove any small flints, pieces of glass, or other sharp material that may have become embedded in the treads.

Do not allow oil or grease to get on to the tyres, as they are destructive to rubber. Wipe the tyre clean immediately if oil or grease gets on accidentally.

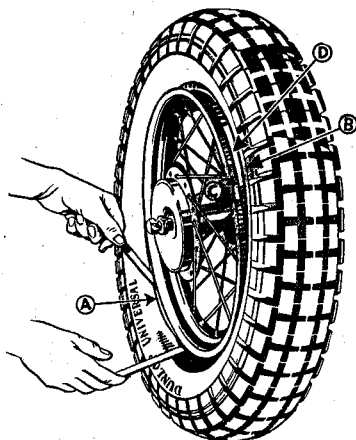

### TYRES. REMOVAL.

No excessive force is needed or must be used either in removing or refitting a tyre, and this will be understood from the following explanation, and illustration (Fig. 64).

The cover bead at "A" cannot be pulled over the flange of the rim until the cover bead at "B" is pushed off the rim shoulder "C" down into the well "D" as the inside diameter of the cover at the cover bead is less than the outer diameter of the rim flange.

First completely deflate by taking off the valve cap and unscrewing the "inside" from the valve. Also remove the valve lock nut which is screwed up against the rim.

Push the cover bead, at a point diametrically opposite to the valve, off the rim shoulder and down into the well, then lift the cover bead near the valve over the flange of the rim with the small lever provided.

Insert another lever close to the first and under the cover bead, see that the opposite bead is right down in the well, and raise another section of the cover over the rim flange. When a small section has been pulled over, the remainder can be pulled away by hand.

Push the valve into the cover through the hole in the rim, and remove the tube. If it is desired to take off the tyre it will come off quite easily without the aid of levers if one bead is pushed into the well whilst the opposite side is pulled over the rim flange.

### TYRES. REFITTING.

Note that wheels are not interchangeable. Inspection of the hubs inside the brake drums will show that only one hub—the rear one—is broached with internal teeth to engage the corresponding driving teeth on the crown wheel shaft. Also note that the ribbed tread tyre must be fitted to the front wheel.

Some new tyres are balanced and have a mark—usually a white spot on the wall—which must be located to correspond with the valve, and some makes are marked with arrows on the walls to show which way round they must be fitted so that the tread runs the correct way on the road.

Refit the "inside" to the valve. Inflate the tube just enough to "round" it but not distend it. Too much air in the tube at this stage will make fitting difficult—too little will render the tube more liable to nipping by the levers when fitting.

Fit the tube into the cover, and pull out slightly at the valve so that it protrudes about 1-in. beyond the beads for about  $4\frac{1}{2}$ -ins. each side of the valve position.

Lay the cover concentrically over the wheel, the overhang being at the valve position and towards the fitter. See that the valve is in line with the valve hole in the rim. Squeeze the beads together at the valve position to prevent the tube slipping back into the cover, and push the valve through the holes in the rim band and the rim. Screw the valve lock nut a few turns only on to the valve.

Allow the lower bead to go into the well of the rim and the upper bead to lie above the level of the rim flange. Working from the valve position press the lower bead over the rim flange by hand. A tyre lever may be used for the last few inches. See that the bead lies right down in the well of the rim. This is important.

Press the upper bead into the well of the rim diametrically opposite the valve. Insert the lever as closely as possible to the point where the bead crosses the rim flange, and lever the bead over the flange. Repeat until the bead is completely over the flange, pressing the bead right down into the well, finishing at the valve position.

Push the valve inwards to make sure that the tube adjacent to it is not trapped under the bead. Pull the valve firmly back into position and inflate to the required pressure. Check the fitting line round the tyre wall at each side to see that it is concentric with the rim flange. See that the valve is square with the rim and screw down the knurled lock nut. Fit the airtight valve cap.

Should the fitting lines not be concentric with the rim flanges, deflate the tyre, centralize it with the rim and re-inflate. By striking the cover sharp blows with a mallet as it is inflated, the cover can often be got on to the rim shoulder evenly all round and the fitting lines concentric.

### FITTING NEW CLUTCH CABLE ASSEMBLY.

Unscrew the saddle springs from their seatings on the frame. Detach the battery leads, remove the battery strap and take out the battery.

If the old cable is broken it will pull away. Should it be unbroken remove the small pivot bolt and nut from the handlebar lever, which will free the lever and allow the nipple to be freed from the trunnion in the lever.

Working through the hole in the bottom of the battery box, disconnect the cable nipple from the shackle on the clutch lever. Withdraw the outer cable casing from the counterbored hole in the stop lug on the gearbox top cover and pass the inner wire through the slot. Pull away the old cable.

Place the new cable assembly in position with the larger nipple at the gearbox end and fit the nipple to the cable shackle on the lever. Pass the cable through the slot in the stop lug and push the outer casing into the counterbored hole in it.

Thread the cable between the top of the radiator and the underside of the frame tube and fit the cable to the handlebar lever. Refit the lever, and the pivot pin and nut.

Adjust the cable by means of the midway adjuster to give  $\frac{3}{8}$ -in. minimum free movement on the cable, measured between the ferrule of the outer casing and the handlebar lever lug.

Take great care that if a Miller generator is fitted, the cable is fitted so that the midway adjuster is prevented from accidentally touching the rectifier, which is bolted inside the frame slightly above and behind the carburetter.

## FITTING A NEW SPEEDOMETER FLEXIBLE DRIVE CABLE.

Remove the battery (see previous section). Unscrew the hexagon nut on the flexible drive casing from the speedometer drive top bearing on the gearbox top cover, accessible through the battery box. Unscrew the knurled ring from the speedometer—accessible from below the left-hand instrument panel. Withdraw the flexible drive towards the front.

Thread the flexible drive over the bottom left-hand fixing bracket of the fuel tank. Engage the tongued rear end of the drive with the slot in the spindle in the gearbox and screw on the hexagon nut to the top bearing. Engage the square end of the flex with the square hole in the speedometer spindle and screw the knurled ring on to the instrument.

Occasionally the flexible drive should be removed and the inner flex drawn from the outer casing towards the rear end for lubrication.

Smear the flexible inner cable with graphite grease and slide it back into the casing, subsequently refitting the drive assembly to the machine.

An unsteady speed indication due to violent fluctuations of the hand may be caused by a dry flexible drive.

## ELECTRICAL EQUIPMENT. B.T.H. TYPE PEC. COMBINED GENERATOR AND IGNITION UNIT.

### GENERAL DESCRIPTION.

The unit is a 6 volt 30 watt permanent magnet generator, the armature of which is mounted directly on the forward end of the crankshaft. The magnet pole assembly is supported in the moulded housing secured to the engine flywheel housing.

The moulded casing contains all the essential components of a coil ignition system, namely:—

An automatic cut-out which opens the generator battery circuit whenever the generator voltage falls below that of the battery.

A six-volt ignition coil.

A contact breaker, the cam of which is centrifugally controlled by governor weights to provide automatic ignition advance in relation to engine speed, and which is mounted with the controlling mechanism on the forward end of the crankshaft.

A condenser which is connected across the contact points.

A two cylinder distributor driven at half crankshaft speed by gearing from the crankshaft.

The wiring diagram is shown in Fig. 65.

## ELECTRICAL EQUIPMENT. MAINTENANCE OF B.T.H. GENERATOR AND IGNITION UNIT.

The unit has been designed so as to need the minimum attention in service, but to obtain the maximum efficiency it is recommended that the following points are checked after ever 5,000 miles running. Removal of the front cover from the generator, after taking off four nuts, makes the items needing attention quite accessible.

### CONTACT BREAKER. (B.T.H.)

Check the gap between the contact points when full open. The correct gap is .012-in., and a gauge is provided and fitted into a recess inside the moulded casing on the left just above the cut-out (Fig. 57). If it is necessary to readjust the gap, first loosen the condenser fixing screw "O" and the screw "E" above it. Reset the gap to the gauge by levering the contact plate in the required direction, using a screwdriver in the slot between the screws. When the correct gap is obtained tighten the screws.

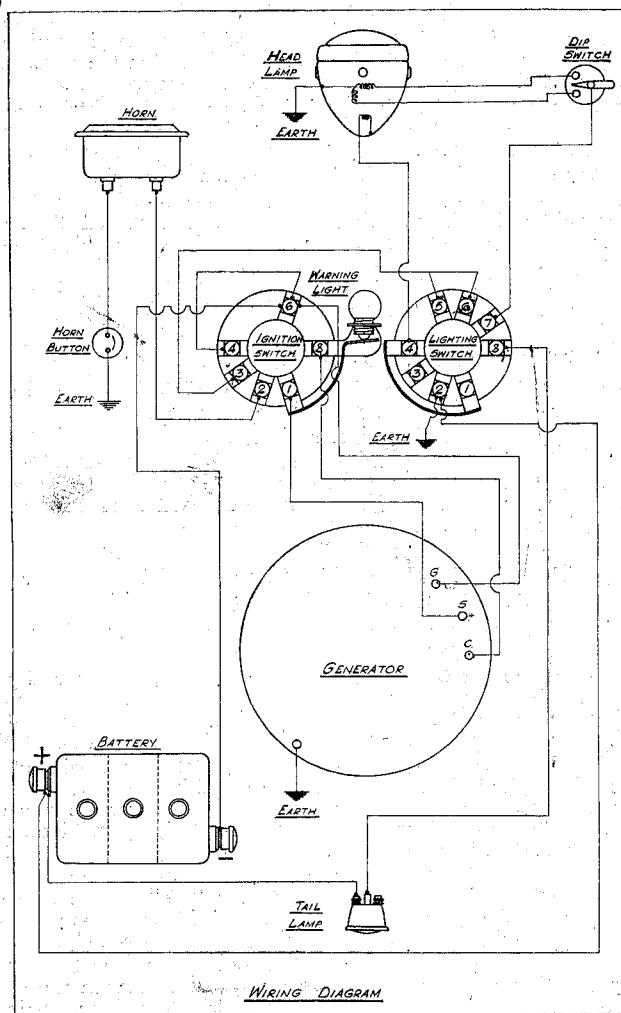

FIG. 65.

Wiring Diagram for B.T.H. Type PEC. Generator.

### Colour Key.

#### IGNITION SWITCH

- Terminal No. 1 Black
- " No. 6 Red and Blue
- " No. 8 Green

#### LIGHTING SWITCH

- Terminal No. 2 Yellow
- " No. 8 White

Yellow lead and one uncoloured to Battery Positive (+)

Blue lead only to Battery Negative (—)



### LUBRICATION. (B.T.H. Generator.)

Oil the contact lever pivot. Put a spot of oil on the pivot pin wick, and a spot or so on the lubricating felt which bears on the cam. Wipe off all surplus oil and particularly keep all oil off the contacts.

Rotate the crankshaft until the timing dots on the distributor gear register with the dot on the crankshaft pinion. Remove the high tension contact strip from the coil and withdraw the distributor gear.

Wipe the bearing pin clean and soak the wick in the pin with light oil (viscosity SAE10) afterwards removing all surplus oil.

Smear a little oil lightly on the bearing pin. Remove all dirt and oil from the moulding around and between the electrodes and also clean the gearwheel.

Replace the gears on the spindle, setting the timing marks in register, and replace the high tension contact strip.

### THE AUTOMATIC CUT-OUT. (B.T.H.)

The cut-out should not need attention in the ordinary way, and unless the generator fails to charge should not be disturbed.

Should adjustment be needed refer to Page 76.

Wipe the interior surface of the moulding and components clean with a dry cloth, or clean out by directing a jet of compressed air over the inside. Do not remove the timing unit unnecessarily. If it is removed, retiming will be needed.

### REMOVAL, ADJUSTMENT AND CLEANING OF GENERATOR COMPONENTS (Fig. 57). (B.T.H.)

If it is necessary to remove or replace any component, the instructions below should be followed.

(a) **Generator Brushes.** The generator brush, spring and fixing plate assemblies may be removed for examination or replacement by removing the screw "A." When replacing, make certain that the appropriate connection lead is securely fixed under the head of "A."

(b) **Automatic Cut-out.** This cannot be taken out without dismantling the entire unit from the crankcase, and it is recommended that adjustment or removal should not be attempted unless there is conclusive evidence that the cut-out is at fault. If the cut-out is suspect it is advisable to consult a B.T.H. Service Station.

(c) **Condenser.** To remove or replace, first take off the nut, washer and spring from terminal "B." Take out screw "O" and the connection tag, when the condenser can be withdrawn. It is important on reassembly to see that the spring and lead connections are refixed securely.

(d) **Contact Breaker.** The contacts may be cleaned in the ordinary way by inserting a strip of fine grade emery cloth between the contact points and drawing it backwards and forwards a few times. Wipe off any dust and dirt with a clean cloth soaked in petrol. If, by this method, the contacts cannot be cleaned satisfactorily, it will be necessary to remove the contact lever, and fixed point assembly in order to clean the contact faces with a smooth oil stone. The utmost care must be taken to keep the faces flat and parallel.

(e) **Contact Lever Assembly.** To remove, take off the springs from the condenser terminal "B" and then remove the spring ring and washer from the contact lever bearing pin "D." The contact lever can then be lifted from the pin. Before replacing the contact lever assembly, lubricate the bearing pin oil wick with one spot of oil, and at the same time smear the bearing pin surface with oil, taking care to remove any surplus oil. After refitting the contact lever assembly, set the gap as previously explained.

(f) **Adjustable Contact Plate Assembly.** First remove the contact lever assembly, then the screws "O" and "E." After the condenser is removed the fixed contact plate can be lifted from the bearing pin "D."

After refitting the contact plate (and also the contact lever) reset the contact gap. See that all surfaces are clean and free from oil.

(g) **Distributor Gear Wheel.** Rotate the crankshaft until the timing marks register. Remove the high tension contact strip from the coil by taking out the screw "F." After withdrawing the gear wheel from its spindle, clean all surfaces including the bearing pin and the distributor moulding with a clean petrol moistened rag to remove dust, dirt and grease. Relubricate the bearing pin as previously instructed. When refitting the gear wheel verify that it is meshed correctly with its marks registering with the marked tooth on the crankshaft pinion.

(h) **Ignition Coil.** This may be removed by taking out screw "F" and the high tension contact strip, disconnecting the low tension leads from terminals "B" and "P," and finally removing the two fixing screws "H." Before replacing the coil clean the whole surface of the coil, particularly the conical ends, and also the main housing surface in the vicinity of the coil with a clean, dry cloth.

(i) **Commutator.** With the ignition coil removed, the commutator is accessible for cleaning. A strip of superfine grade glass paper should be pressed lightly against the surface of the commutator, whilst the engine is rotated by hand. After cleaning blow away all dust and wipe the moulding surface clean.

(j) **Cam and Automatic Timing Unit Assembly.** It should seldom be necessary to remove this except to retime the ignition or to remove the generator. Great care is necessary during removal. First remove the distributor gear wheel and then the timing unit fixing screw "J." Insert the extractor bolt LET801 and tighten down until the assembly is released from the flywheel shaft.

### GENERATOR OUTPUT. B.T.H. TYPE PEC.

Experience has shown that occasionally the generator output tends to increase after several hundred miles running, in some cases sufficiently to cause excessive brush wear.

This can be remedied by re-adjusting the output, which should be 5 amperes 6.5 volts at 3,000 r.p.m. (or 30 miles per hour in top gear). The output can be checked on the motorcycle by connecting up temporarily a D.C. Ammeter in the generator to battery circuit. The tests can be made on the road running at 30 m.p.h. in top gear, or with the motorcycle stationary and the engine speed checked with a portable tachometer.

To re-adjust the output, remove the contact lever assembly, loosen the three brush plate fixing screws and the contact lever pivot. Move the brush plate slightly in the direction of rotation of the commutator.

Tighten the brush plate screws and the contact lever pivot, refit the contact lever. Start the engine and check the output.

Generally the optimum brush position for the specified output is when the lower (position) brush box is moved in the direction of rotation until a  $\frac{1}{16}$ -in. diameter drill can just be inserted between the forward edge of the brush box and the moulded boss to which the contact plate is secured. Time will be saved if the brush box is set to this position prior to rechecking.

For the best all-round performance, the distance between the moulded boss and the edge of the brush box should never be more than  $\frac{1}{8}$ -in., but can be less than  $\frac{1}{16}$ -in.

Where no facilities are available for checking the output, check the distance between the moulded boss and the forward edge of the lower brush box, and if greater than  $\frac{1}{16}$ -in. reset to this distance.

If, on the contrary, the generator is not charging or engine will not start on the "Emergency" position, first check all wiring connections to switch board. Particularly see that the "jacks" or plug connections are pushed fully home. Should these points be in order check the voltage as follows:—

Disconnect the positive bottom brush from the earth pin "S" (Fig. 57) and connect in a Voltmeter between brush and terminal "S."

A reading of 12 to 15 volts should be obtained at 3,000 r.p.m.

If the voltage is correct and still no charge is obtained when re-connected, suspect the shunt wiring or cut-out. Check, and if necessary, reset the cut-out gap to .040-in. with .015-in. clearance between the plate SKC.22638 and the shunt wire pole (or core) with the points closed.

### ELECTRICAL EQUIPMENT. LIGHTING. HEADLAMP MILLER 63E.

To remove the lamp front and reflector undo the screw at the bottom of the lamp and pull the rim away from the bottom first. The reflector will not come right away without detaching the leads to the bulb holders, or releasing the bulb holder securing springs and withdrawing the holder from the reflector.

To take out the reflector or to fit a new headlamp glass release the four—or more—securing clips from under the lip of the rim which will free the reflector and the glass.

Do not touch the reflector inside on the polished reflecting surface, as finger marks will be left which it will be difficult to clean off without permanently damaging the surface.

When replacing the reflector see that it is the right way up with the pilot lamp opening at the top. Refit the lamp front at the top first. Engage the screw and tighten.

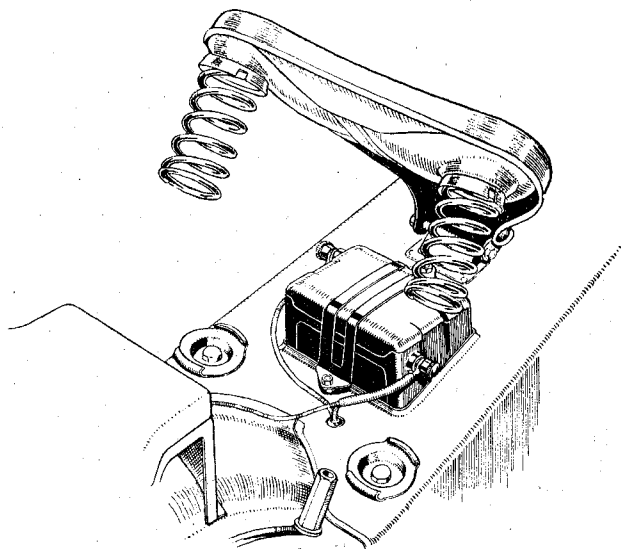

FIG. 66.

### BULBS.

When buying replacement bulbs be sure to get the correct type. The bulbs fitted are:—

Main bulb: 6 volt 24×24 W. double filament S.B.C.  
Pilot bulb: 6 volt 3W S.C.C.

### TAIL LAMP—MILLER 36E.

To remove the bulb, spring out the circlip from under the lip around the plated fret, pull out the fret and ruby disc. The correct bulb is a 6 volt 3W. S.C.C.

### THE BATTERY.

Two different types of accumulators have been used as standard equipment at different times, namely the Varley dry accumulator, and the normal "wet" type Exide. The treatment of these two types varies, and will be dealt with separately. Both types are accessible by unscrewing the saddle springs from their bottom fixings and hinging the saddle forward (Fig. 66).

The battery is then clear for topping up or removal by detaching the battery strap and disconnecting the electrical leads.

### THE VARLEY 6V. 12 A.H. BATTERY TYPE MC17/12. INITIAL FILLING AND FIRST CHARGE INSTRUCTIONS.

If the battery has not already been filled with acid and received its first charge, remove the vent stoppers and fill, employing one of the methods given below.

Only Sulphuric Acid of the best accumulator grade must be used. Specific gravity (sp. gr.) to be as follows:—

Temperature climate ..	1.275
Warm climate .. ..	1.250
Tropical climate .. ..	1.225

1. Use the special Varley Motor Cycle filler cup. Place the cup over the top of the battery with the battery on a level surface, and fill each compartment of the filler up to the top. Allow to stand until all acid has percolated through into the battery. Charge within an hour.

2. Completely immerse the battery in acid of the correct sp. gr. in an acid resisting container of suitable size, taking care that the acid level is above the vents. AFTER ONE HOUR and NOT MORE THAN ONE HOUR of soaking, remove the battery, wipe it clean and dry and put IMMEDIATELY on charge.

3. Fill each vent separately and keep refilling until each of them remains full for at least five minutes. It can then be assumed that the full complement of acid has been absorbed and the battery should be put on charge within one hour of the commencement of filling. The filling takes about half-an-hour.

The approximate amount of acid the battery will absorb is one pound, or  $\frac{3}{4}$ -pint (.378 litre).

It is of the utmost importance that the battery receives its full quantity of acid upon which depends the satisfactory performance and life. The porous block of plates and separators in a Varley dry accumulator obtains all the acid necessary for functioning by a SOAKING process, which is comparatively slow. To ensure therefore that the battery is fully saturated it is essential that during the whole of the first charge period the battery is topped up with the correct sp. gr. acid which should be visible in the ventholes. No distilled water should be added during the period of the first charge, which should begin within one hour of the commencement of filling. FIRST CHARGE INPUT 90 a.h. at a rate not exceeding 1.5 amperes (i.e., 90 hours at 1 amp. or 60 hours at 1.5 amps).

During the final stage of charge the voltage of the battery should read 7.8 volts, that is 2.6 volts per cell, and every cell should be gassing freely.

The battery should then be wiped with a wet rag, or washed in water, dried, and the vent stoppers screwed in (remove sealing tape, if any).

Before connecting up, grease the terminals lightly with vaseline.

The first charge period should be continuous, and it is not advisable for the current to be switched off until completion. If for any reason the current has to be cut off the open circuit standing time should be allowed for.

#### MAINTENANCE.

In normal use the generator on the machine will keep the battery charged. It will need topping up once a month with a small quantity of distilled water. The vent holes should not be flooded, but the inside of the vents should be moist.

When standing idle a battery must be given a freshening charge off an independent source of supply at least once a month. 8 hours at 1 amp. is recommended.

Keep the battery clean and dry. The brass terminals should be lightly smeared with vaseline from time to time.

#### RECHARGING.

Should the battery have become discharged recharge at once at 1 amp. for 16 hours, and if the battery was allowed to become abnormally dry it should be topped up with distilled water before and during charge. If any water is present in the vent holes at the end of the charge it should be emptied and the battery washed and dried.

**NOTE.** MILLER AND B.T.H. SETS ARE WIRED WITH THE POSITIVE TERMINAL TO EARTH. (Figs. 65 & 69.)

#### THE EXIDE 3EK5LF2.

If the battery has not already been filled with acid and received its first charge, remove the vent stoppers and break seals in openings.

Use only best accumulator grade Sulphuric Acid Sp. grs. as follows:—

In climates with air temperatures ordinarily below 90°F. (32°C.):—  
1.310 Sp. gr.

In climates with air temperatures ordinarily above 90°F. (32°C.):—  
1.230 Sp. gr. ("low" gravity).

Fill each cell to  $\frac{1}{4}$ -in. above the tops of the separators. Replace vent stoppers and allow to stand for 12 hours. Top up the acid to the original level.

#### FIRST CHARGE.

Charge at  $\frac{1}{4}$  ampere for 96 hours. In urgent cases only the battery may be charged at 1 ampere for 70 hours, but the slower charge is advisable and recommended in preference.

The charge may be interrupted provided that the charge periods are of at least 8 hours and the rest periods do not exceed 16 hours.

The battery is not completely charged until the total charging time specified for the rate of charge employed has been given.

**NOTE.** Should the temperature of the acid reach 110°F. (43½°C.) in the "temperate" climatic conditions, or 125°F. (52°C.) in the warmer conditions noted previously reduce the charge current and increase the time proportionately or suspend the charge.

The voltage and specific gravity of each cell must remain constant and even for successive hourly readings, and each cell must gas freely.

When the above conditions are noted the battery can be considered charged. On completion of charge, the specific gravity of the acid in each cell should not exceed 1.285 (with "low" gravity acid 1.215). If it does, withdraw some acid from the cell and replace with approved water (preferably distilled); charge for another hour and test again.

Adjust the acid level to  $\frac{1}{4}$ -in. above the tops of the separators. If the level is high withdraw excess. If too low add acid of 1.280 Sp. gr. (with "low" gravity acid 1.210).

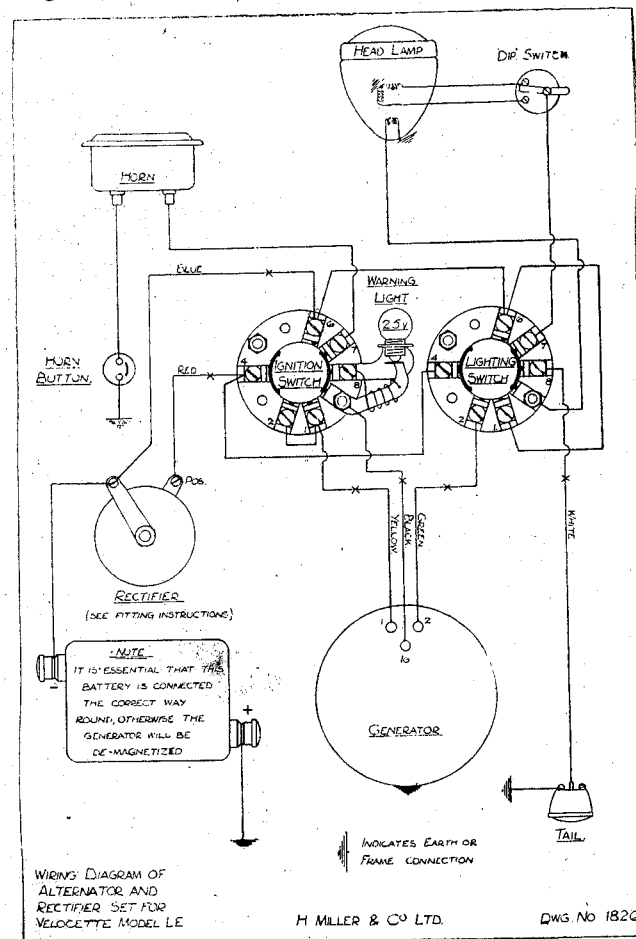

FIG. 69. Wiring Diagram for Miller Type AC3 Set. (Used on Machines prior to Eng. No. 200/15840.)

#### MAINTENANCE.

Keep the vent plugs tight. See that the battery and particularly the tops of the cells are clean and dry. Keep the terminals and connections free from corrosion and smear lightly with vaseline.

The acid level must be checked at regular intervals of one month, or more frequently in hot conditions, and distilled water added as needed to restore the level to  $\frac{1}{4}$ -in. above the tops of the separators.

**NOTE.** It is probable that more batteries become unserviceable due to neglect than to fair use, and the preceding instructions, particularly when they refer to topping up should be followed. The battery is easily accessible for attention and topping up, takes but a few moments and can be done at a time when a routine check of tyre pressures, and oil and water levels is being carried out. If the battery leads are disconnected note that **THE POSITIVE TERMINAL IS CONNECTED TO "EARTH."**

Overfilling will cause acid to leak out of the filler plug vents and cover the top of the battery. This causes a constant discharge due to the current being conducted across the top of the battery between the terminals by the wet surface.

Topping up is best done just before a run, so that the agitation caused by road vibration and the gassing caused by the charging will thoroughly mix the solution.

Should the machine be stored for more than a few weeks steps must be taken to prevent the battery deteriorating. A battery left standing in a discharged state rapidly becomes useless due to sulphating of the plates. To store a battery, first see that the acid level is correct and have it charged from a separate source of electrical energy. Once a month give the battery a freshening charge of 8 hours at 1 ampere.

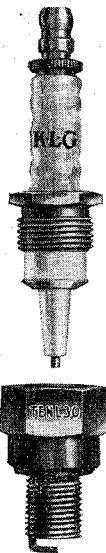

#### SPARKING PLUGS.

When buying replacement sparking plugs be most insistent that the correct grade of plug is obtained. All makes are available in many different types even in the same diameter thread. The length of thread varies—the model LE takes 10 m/m diameter by  $12\frac{1}{2}$  m/m reach—and plugs are graded in different degrees of internal heat resistance. The makers designate the various types and grades by the use of type letters and number, so that the buyer must ask for the exact type needed as well as specifying the make. Do not use plugs of shorter reach than  $12\frac{1}{2}$  m/m.

The recommendations for the LE are: K.L.G. type Ten L30, Champion Y7, or Lodge CL10.

From time to time remove the sparking plugs for cleaning and re-setting. This can often be done for a few pence by a Service Agent who has installed a sparking plug cleaning and testing apparatus. Make certain, however, after cleaning on such equipment that no traces of sand which is used to scour out the plugs is left in the gas spaces. Have them well blown out with compressed air, otherwise the sand may get into the cylinders, with serious consequences to the engine.

Plugs may, however, be cleaned by other means as follows:—

FIG. 67.  
A K.L.G. type Ten L30 Plug.

Detachable types of sparking plug (See Fig. 67) may, as the description implies, be taken apart for cleaning.

To take apart unscrew the gland nut from the body of the plug, this is the smaller hexagon, and withdraw the insulated central electrode. The gland nut is best loosened by holding the larger hexagon in a vice, being very careful to tighten the vice only enough to hold it, otherwise it may be crushed and distorted. Unscrew the gland nut with a closed ended, or tubular spanner. Retain the internal copper washer.

Clean thoroughly in petrol and scrape off all accumulations of carbon or oil. Coarse glass paper may be used. Scrape the plug body clean with a penknife or wire brush and rinse in petrol.

Lightly smear the internal copper washer, used between the insulator and the plug body, with thin oil, see that it seats properly and refit the central electrode. Screw in and tighten the gland nut.

"Non detachable" types may be cleaned by wire brushing the firing points and washing in petrol.

The plug gap will require resetting after cleaning. The gap should be .020-in. and must be set by bending the "earth" electrode attached to the plug body. **Do not in any circumstances attempt to bend the centre electrode—this would crack the lower end of the insulator and ruin the plug.**

#### THE CARBURETTER. EXPLANATION OF WORKING.

The main reason for the evolution of the small carburetter (used on the L.E. Model) which contains an air bled compensating jet system was to provide more pronounced compensation of the main jet system, which point was considered of paramount importance with such a small capacity engine, which, due to its particular lay-out, would be subject to throttle abuse in top gear and might, in some circumstances, be driven almost to a standstill in top gear before a gear change was made.

To obtain this it was necessary to use a high degree of compensation, which accounts for the complication of the design.

It was also found on test that the jet settings in this carburetter were exceptionally critical, and it is, therefore, important that in no circumstances should the jet sizes be altered.

The setting which has been obtained as a result of lengthy tests gives perfect satisfaction, and any unsatisfactory running which can be traced definitely to carburation will be found to be due to partial stoppage of one or more of the jet combination, and having thoroughly removed this, preferably by blowing with an air line, it will be found that satisfactory running will be restored.

The fuel enters the carburetter via a petrol union nut and nipple, and flows into the filter bowl through hole "A" (Fig. 68). From here it passes through a special Filter Element "B," which prevents the passage of foreign matter. From the filter the fuel passes to the float chamber via the needle and seating "C," a constant level being maintained by the normal type of float.

Fuel then feeds from the float chamber to the Platform "D," where it is fed to the various jets of the system.

Dealing first with the starting system, fuel is fed through the starting jet "E," which is 15 c.c. and passes to a small auxiliary starting chamber "F," which can be put in or out of operation by the control lever "G." When the lever is pulled to the "Start" position, fuel is fed from the 15 c.c. starter jet up the vertical passage marked G1 in the small section sketch, and is intimately mixed with air, which is supplied via the small hole G2 in the casting. The resultant mixture—which is of necessity of rich proportions—is fed to the engine through the duct "G3," which is on the engine side of the throttle. Consequently, this rich mixture which is supplied without any necessity for either flooding the carburetter or opening the throttle insures an instantaneous start.

The device, of course, is then pushed out of action immediately sufficient temperature has been obtained to enable this to be done.

Now under normal running conditions the slow running is obtained by means of the Pilot jet "H," which is a 30 c.c. jet; this supplies slow running fuel which is mixed with pilot air entering the air hole in the intake "I," which in turn is adjusted by means of the air screw "J," and the total volume of this mixture for slow running purposes is then controlled by the Pilot Spray Tube "K," which is 25 c.c.

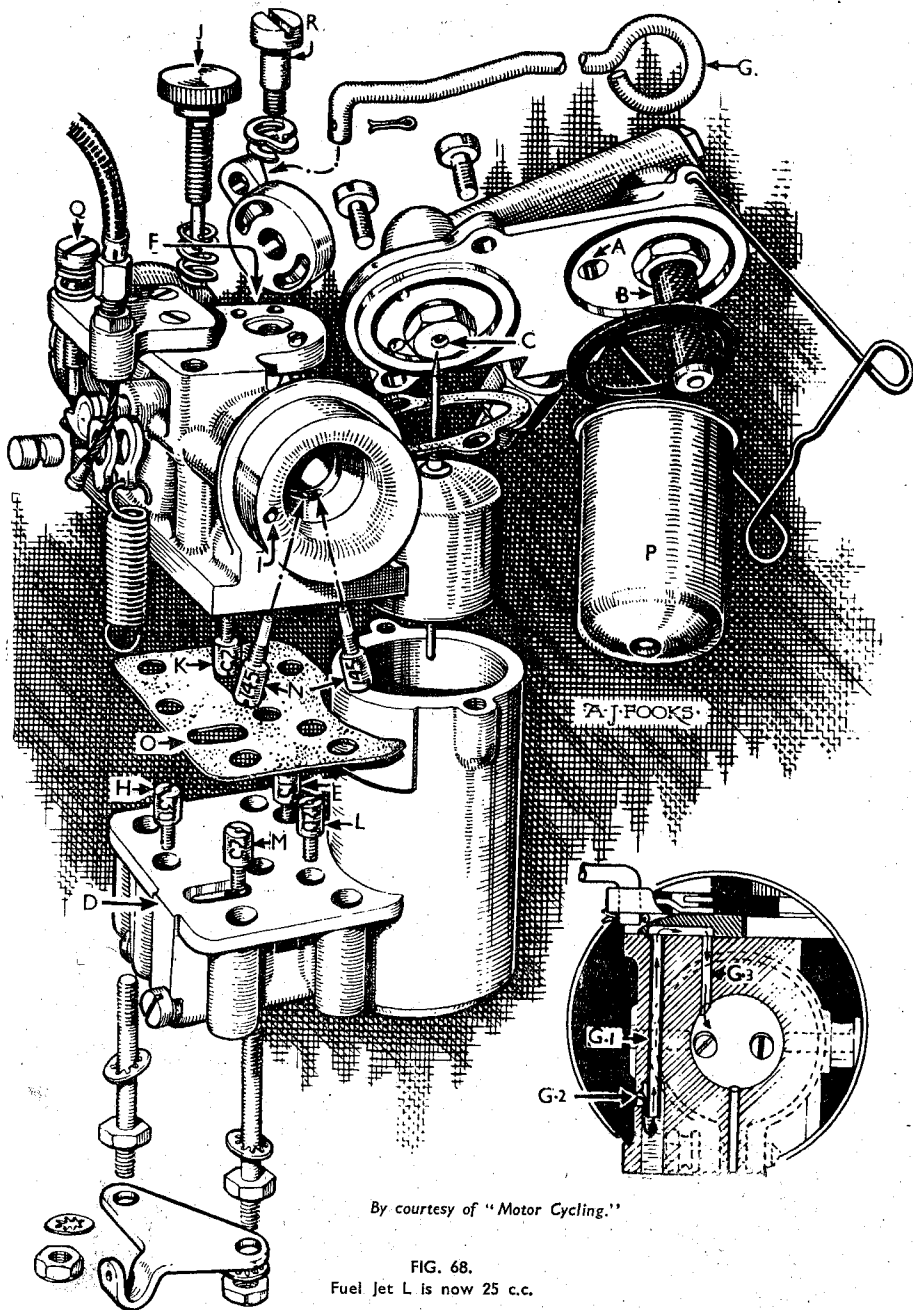

By courtesy of "Motor Cycling."

FIG. 68.  
Fuel Jet L is now 25 c.c.

It will thus be seen that although the total volume is controlled by the jet "K," and the total fuel supply is controlled by the jet "H," by means of the adjusting screw "J," a varying mixture strength can be obtained to suit varying engine slow-running characteristics and thus air screw "J" should be adjusted to give the desired tick-over on any particular engine.

A small bridging hole of .040-in. diameter is drilled just on the atmospheric side of the outlet of the pilot column jet "K," its function being to bridge the mixture strength on a position of throttle opening where the depression is falling off on the pilot volume jet "K," and has not yet built up sufficiently on the main jet system.

Dealing now with the main jet system, this consists of the well-known main and compensating jets, the former being fully subject to engine depression unbled, and the latter being bled to atmosphere. This results in the discharge from the main jet increasing and decreasing according to engine depression, whereas the flow from the compensator jet richens or weakens out of proportion according to the engine r.p.m. By this is meant that for example, with a plain jet system with an engine which is pulling up a long hill in top gear, as the r.p.m. fall off, the main jet discharge falls off considerably, which would normally result in an ultimate stalling of the engine, whereas with the compensator jet system the air supply falls off out of proportion to the fuel supply, due to its lesser density, and a richening effect is maintained resulting in a normal petrol-air ratio being held on to, and in consequence, better pulling power is maintained at lower r.p.m.

The inverse, of course, takes place as the engine revolutions increase, this in turn again producing a more uniform mixture curve.

We thus have the main fuel jet "L" and the compensating fuel jet "M," the former being 25 c.c. (SHOWN INCORRECTLY IN ILLUSTRATION AS 20 c.c.) and the latter also 25 c.c. The latter, it will be noticed, is bled to atmosphere via a vertical air duct to the air hole "I," which has been mentioned previously.

The volume supplied to the motor by these two fuel jets is controlled by the spray tubes "N," which are both 145 c.c. Both these spray tubes enter the throat of the choke radially at a slight angle one to the other, and deliver their mixture volume from a fairly low throttle opening up to full throttle.

It will thus be seen that the volume of this mixture can be controlled by the spray tubes "N," and the quality of it is controlled by the main jet "L," or compensating jet "M."

#### THE CARBURETTER. DISMANTLING, CLEANING, RE-ASSEMBLING AND RESETTING.

It is unavoidable that occasionally the jets or passages in the carburettor may become partially choked by foreign matter from the fuel. Even the most efficient filter has not proved capable of preventing this ever occurring.

Should the engine begin to run unsatisfactorily and this be thought to be due to carburation it may not be necessary to remove and dismantle the carburettor to clear it, and it is worth while trying to remove the restriction in the following manner.

Start the engine and raise the machine on to the stand. Slide the rubber sleeve connecting the carburettor intake to the air cleaner off the carburettor intake. Increase the engine speed by sharply opening the throttle about half way, and when it has accelerated push a finger into the carburettor intake to prevent air entering. This will tend to stop the engine, but before the engine stops, remove the finger and allow the engine to pick up speed again, and when it has done so repeat the "choking."

After doing this a few times, slide back the rubber sleeve into place and test the machine on the road to see if the carburetter is cleared.

Should this fail, check the joints between the induction pipe and cylinders for air leakages, as this may be responsible for unsatisfactory running, and the point is worth investigating before dismantling the carburetter.

The body of the carburetter, which is in two halves, is made from zinc-base alloy die cast, and can be dismantled by slackening off the five nuts at the base, when the float chamber half, complete with all jets, can be withdrawn. This then leaves the top half complete with the filter assembly and the three spray tubes referred to previously.

Care should be taken that the washer "O" is not damaged. The filter bowl "P" can be removed for cleaning purposes by slipping off the wire stirrup which holds it in place, and the filter element removed for washing in clean petrol and blowing out with air.

Unscrew and remove the three 1/8-in. diameter screw-headed plugs from the carburetter base, they are fitted in the sides, and remove all the jets, blow air through all the passages to clear any obstruction or foreign matter. Be careful to note the places from which the jets are removed, and make certain that they are refitted in the same positions.

When reassembling, make certain that the washer "O" is in good condition, and if damaged in any way fit a new one.

The carburetter must be fitted horizontal, and can be easily set by placing a steel rule or straight edge across the machined face of the float chamber cover before refitting the filter bowl or if this is already fitted, between the bowl and the spring clip.

For retuning the slow-running end of the carburetter a throttle stop screw "Q" is provided, which should be adjusted to give the best possible tick-over in conjunction with the air adjusting screw "J." The throttle stop screw "Q," of course, simply provides a mechanical stop for the opening of the butterfly valve; the screw "J," as explained before, controls the mixture strength for slow running.

A periodic inspection should be made that the screw "R" is tightened right down, as otherwise an air leak may take place across the faces of the starter valve, which will cause difficult starting.

In conclusion, therefore, this carburetter, although appearing somewhat complex in its design, does give a very good and definite control of the mixture strength on such a small engine, due to its various jets, and it cannot be emphasised too strongly that the greatest disturber of this consistency of running, is foreign matter, and absolute cleanliness is therefore essential in all ways. Before any violent decisions are made with regard to the running of the machine, scrupulous care should be taken in cleaning out the carburation system to make certain that a partially stopped orifice is not the root cause of the trouble. Also suspect air leaks at the induction pipe flange joints to the cylinders.

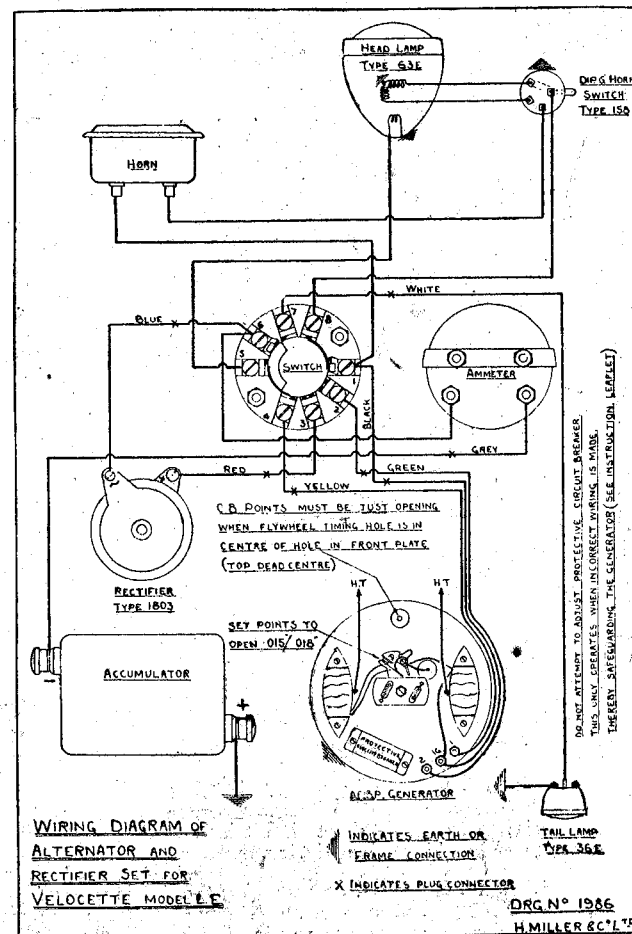

FIG. 71.

Wiring Diagram for MILLER Type AC3P Set.  
Applicable to Machines after Engine No. 200/15840.

## THE MILLER GENERATOR SET (Types AC3 and AC3P).

**Description.** The generator consists of a stator plate (aluminium casting) carrying on the outside two high tension coils, a contact breaker, a condenser, and in the case of the type AC3P set, a protective circuit breaker. These are visible when the front cover is removed.

On the reverse side of the stator plate there are three low tension generating coils secured to the casting by six (2BA) screws.

To complete the generator there is the magnetic rotor (flywheel) consisting of a brass wheel carrying six magnets, six soft iron poles and a steel centre hub.

The rotor or flywheel is fixed to the flywheel shaft of the engine by a nut, the shaft being tapered to receive the tapered bore of the flywheel.

**Removal of Cover.** Take off the two fixing nuts and pull off the cover. Do not at any time remove the cable-support pressing unless this is damaged. This pressing is secured to the stator plate by two (2BA) screws.

**The Contact Breaker.** The contacts must be kept free from oil at all times. Wipe them occasionally with a petrol soaked rag, making sure that no lint is left on the contacts. Should this fail to clean them satisfactorily, polish with fine emery cloth. If small "pips" are formed on the contacts remove these by filing or stoning, making sure that the surfaces are left truly flat and then readjust the gap. With the contacts fully open the gap must be .014-in. to .018-in. This clearance is critical and must be accurately set. See also Page 50.

When the generator is working a small amount of sparking is desirable, but should this become violent and excessive the condenser should be suspected of being at fault and should be tested.

**The Condenser.** Should there be excessive sparking at the contact breaker points when running with the switch on "Normal running" or "Charge and Ignition", the condenser may be at fault.

To remove the condenser take out the round head screw and washer holding the condenser bracket to the stator plate, and uncouple a similar screw connecting the condenser lead to the contact breaker terminal.

To test the condenser apply a D.C. lighting mains voltage to the terminal of the condenser and to its container, using a lamp of suitable voltage in series to prevent a short circuit in the event of the condenser proving faulty or breaking down during the test.

If the Condenser is in order, on removing the mains voltage and after a pause of a few seconds an appreciable snappy spark will be obtained on short circuiting the condenser lead to the container.

If the condenser is leaky or partially short circuited no spark will be obtained, and a replacement condenser should be fitted to the generator.

**The Automatic Timing Unit.** This requires very little attention in service. Should it be necessary at any time to remove it refer to Page 50. When refitting after retiming fill the cavity between the end of the engine flywheel shaft and the end of the tapered hole with gear oil (Castrol Hi-Pre or similar) and replace the fixing screw, making certain that the timing is correct before finally tightening it. Do not overtighten the fixing screw, as this may expand the sleeve on which the cam moves.

**The Cam Lubricating Pad.** Apply a little light grease to the pad every 2,000 miles. Do not overgrease as the surplus may get on to the contacts.

**Warning.** The rotor of any Miller set Type AC3 as used on machines before Engine No. 200/15840 will become demagnetised if the battery is connected up incorrectly. Always refer to the wiring diagram, Fig. 69, Page 83 if in doubt. The positive battery terminal (+) is connected to "earth".

## THE MILLER GENERATOR, TYPE AC3P. (Fitted from Engine Number 200/15840 onwards).

This generator is similar in design to the Type AC3 and a description of both types is given in the preceding section. It is, however, fitted with a protection circuit breaker (which must not be adjusted or tampered with) in order to prevent demagnetisation of the rotor should the set inadvertently be wired up incorrectly to the battery.

Should the ammeter indicate a discharge with the engine running and the switch in the "Charge and Ignition" position, the engine must be stopped at once and all connections examined and verified by the diagram, Fig. 71.

First examine the battery connections to see if these have been attached the wrong way round. The positive (+) battery terminal must be connected to "earth."

*Do not delay correcting the circuit or the battery will become discharged—also do not attempt to adjust the circuit-breaker.*

**The Switch Panel, Type LAS/87/3.** The lighting and ignition circuits are controlled from one switch, and an ammeter is fitted. There are six positions for the switch, which may be locked in the "off" or "Park" positions. The positions are "Park, Emergency Start, Off, Charge and Ignition, Head and Tail, Pilot and Tail.

*The emergency position is to be used only if the battery has become discharged, and cannot provide current for starting in the CH and IG position.*

*Switch over to CH and IG position as soon as the engine is running.*